

P7001 Standard Kit FITTING INSTRUCTIONS

For use with 44mm thick doors only
For Single and Double doors

IF INSTALLING A TOUCH LATCH OR GRAVITY CLOS-



(Image for reference only)

SUGGESTED TOOLS



DRILL



G-CLAMP



TAPE MEASURE



HACKSAW



PLUMB LINE



HANDSAW



SPIRIT LEVEL



PROTECTIVE EQUIPMENT

COMPONENTS

POCKET DOOR KIT

- SHORT / LONG 'Z' SECTION *
- LONG 'Z' SECTION *
- TRACK PACKER *
- PLYWOOD TRACK MOUNT *
- ALUMINIUM TRACK *
- DOOR BOTTOM CHANNEL *
- SOLE PLATE *
- RUBBER SEAL *
- BRUSH SEAL *

DOOR JAMB SET

- HEAD SECTION *
- FRONT EDGE JAMB *
- CASSETTE EDGE JAMB *

SLIDING MECHANISM

- TROLLEY CATCH *
- TROLLEY ASSEMBLY *
- FLOOR GUIDE *

FIXING ITEMS

- END BLOCK *
- PROTECTIVE EDGE CLIP *
- CHOCK LARGE *
- CHOCK SMALL *
- SCREW SET A *
- SCREW SET B *
- SCREW SET C *
- SCREW SET D *
- SCREW SET E *
- SCREW SET F *

* Quantities are dependant on type of kit ordered

POCKET DOOR KIT

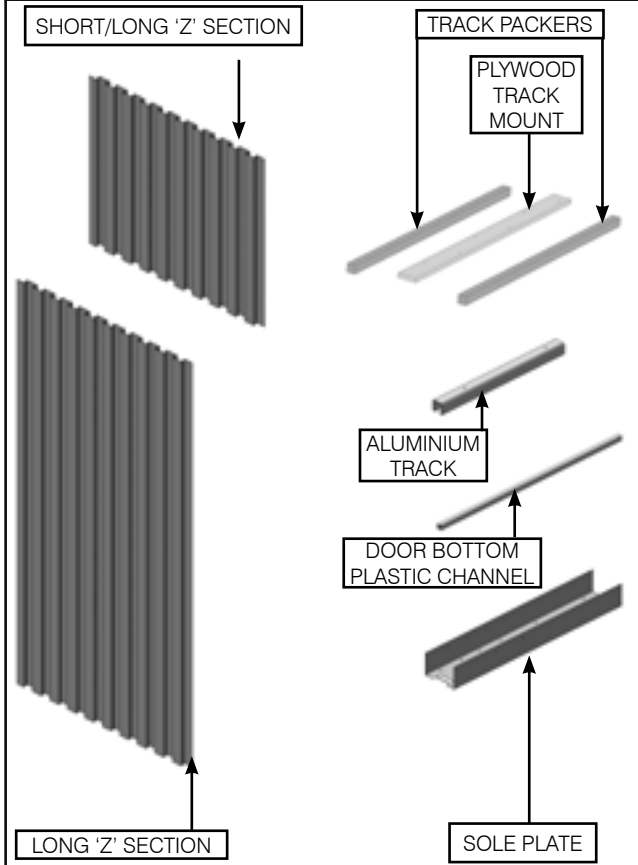

SLIDING MECHANISM

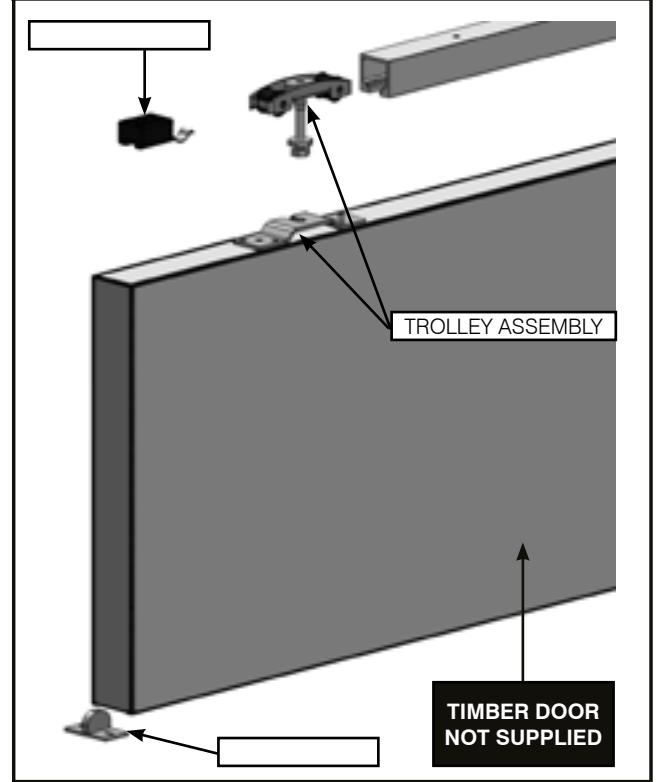

OPTIONAL DOOR JAMB SET

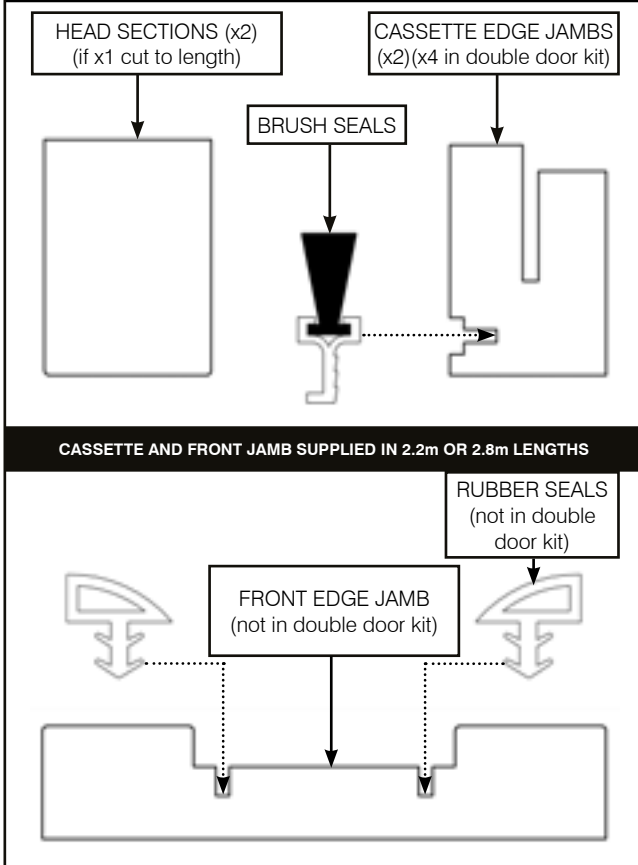

FIXING ITEMS SET

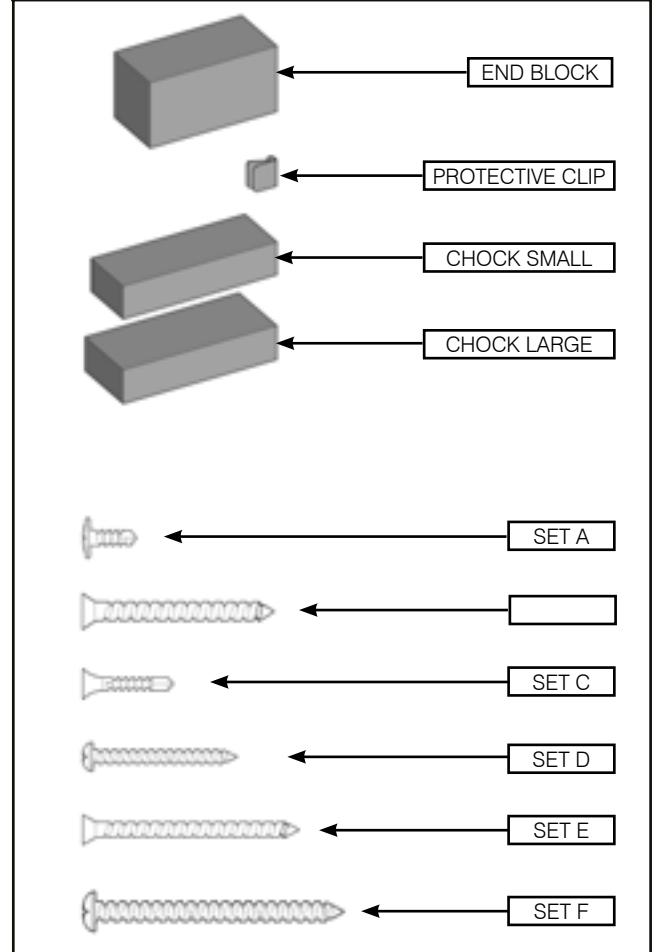

PRE-DOOR FITTING INFORMATION

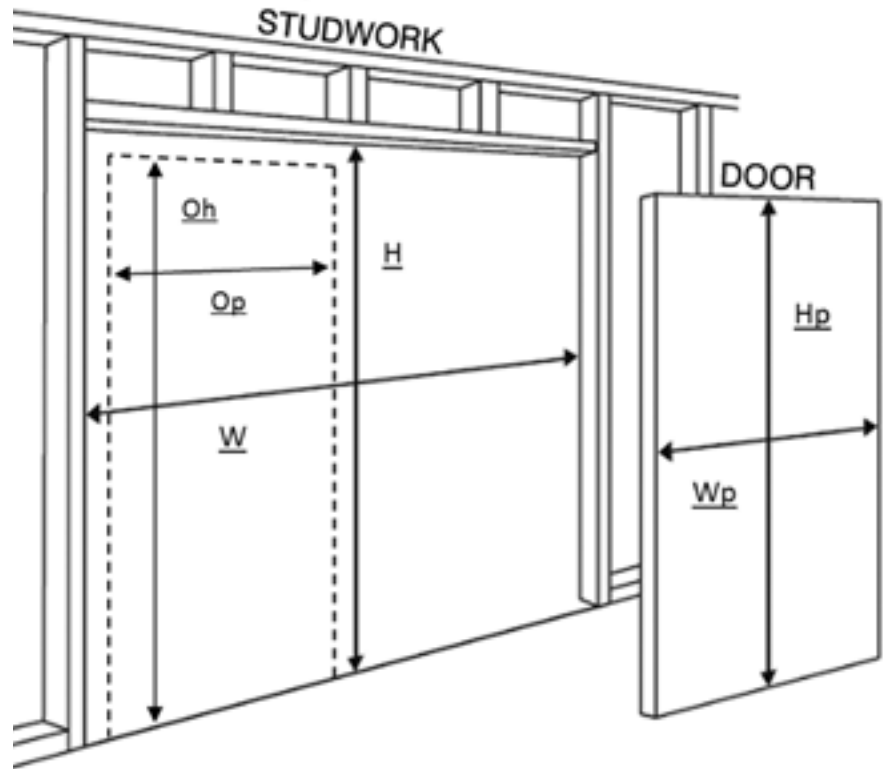

Abbreviations

W = STUDWORK WIDTH

H = STUDWORK HEIGHT

Op = DOOR OPENING WIDTH

Oh = DOOR OPENING HEIGHT

Wp = DOOR WIDTH

Hp = DOOR HEIGHT

1. To calculate **studwork** width and height from known **door dimensions**:

Studwork width (W) = (2 x Door width (Wp)) + 66mm
 Studwork height (H) = Door height (Hp) + 85mm

For double doors: (W) = (4 x (Wp)) + 94mm
 For double doors: (H) = (Hp) + 85mm

2. To calculate **door size** from known **studwork dimensions**:

Door width (Wp) = (Studwork width (W) - 66mm) / 2
 Door height (Hp) = Studwork height (H) - 85mm

For double doors: (Wp) = (W) - 94mm / 4
 For double doors: (Hp) = (H) - 85mm

door size opening dimensions:

Door width (Wp) = Door opening width (Op) + 23mm
 Door height (Hp) = Door opening height (Oh) + 4mm

For double doors: (Wp) = (Op) + 34mm) / 2
 For double doors: (Hp) = (Oh) + 4mm

4. To calculate **door opening** width and height from known **door dimensions**:

Door opening width (Op) = Door width (Wp) - 23mm
 Door opening height (Oh) = Door height (Hp) - 4mm

For double doors: (Op) = (2 x (Wp)) - 34mm
 For double doors: (Oh) = (Hp) - 4mm

1. TRACK MOUNT

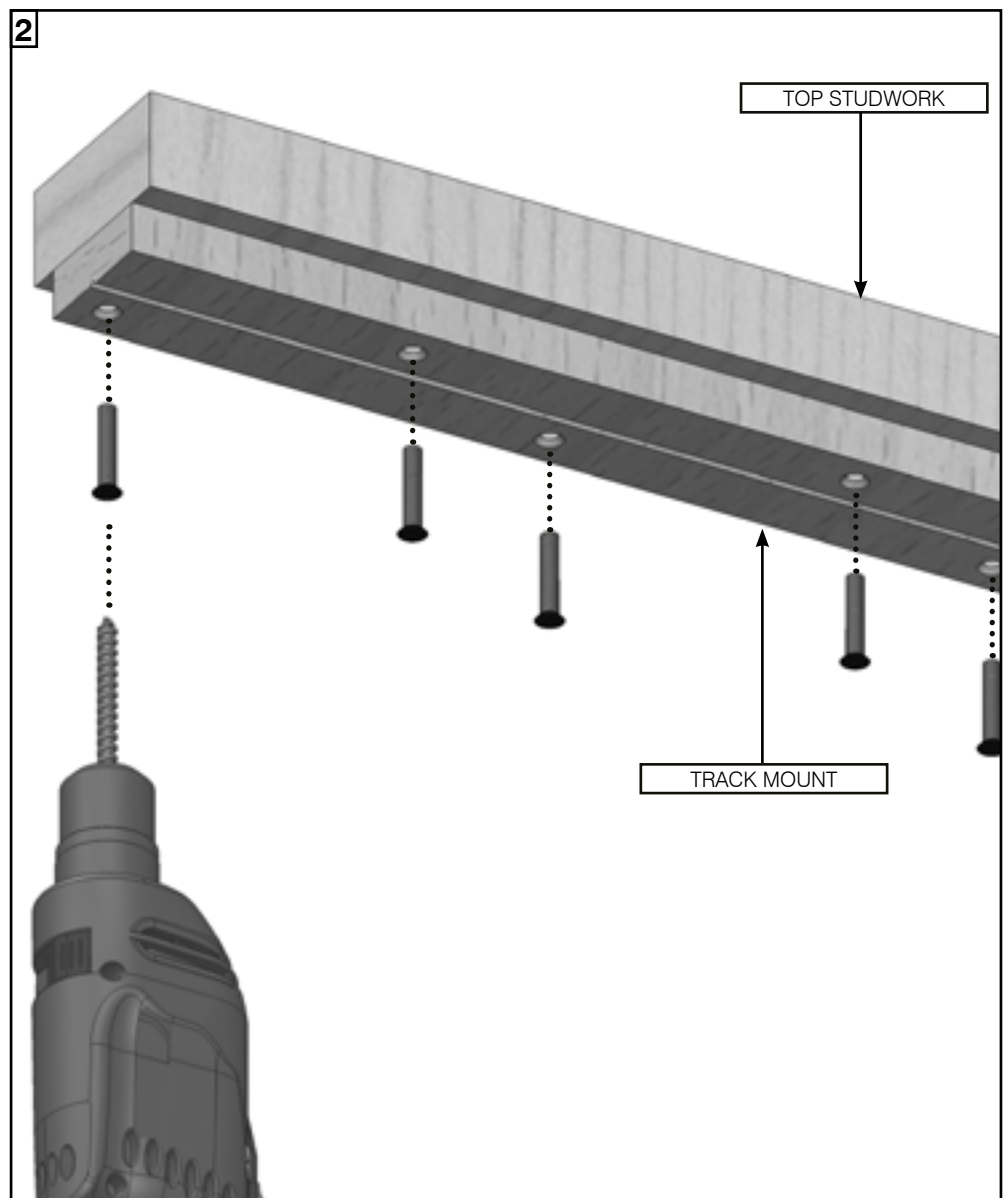
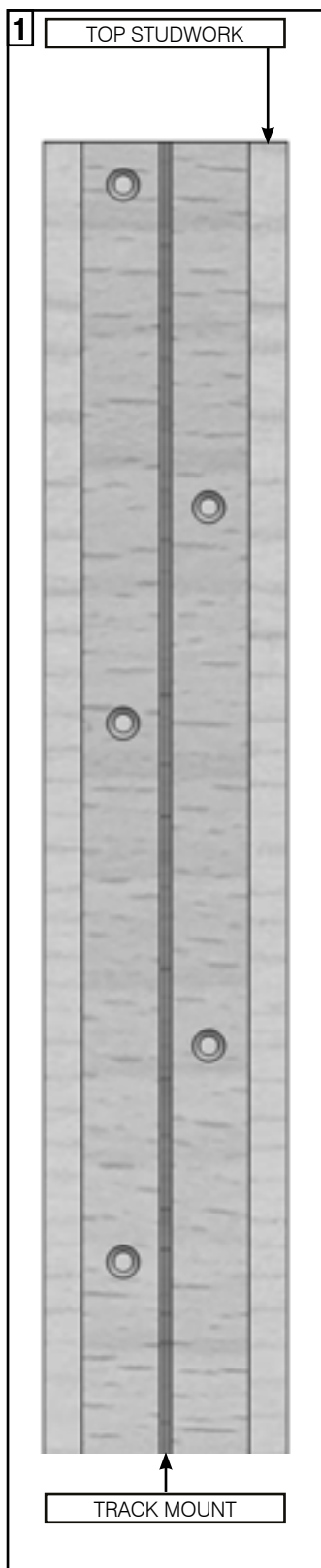

1. Cut the plywood track mount to the width of your horizontal studwork / support frame.

For intermediate, wide and double kits butt the two track mounts together to make up the required length

2. Position the track mount in the centre of the top horizontal studwork timber / support frame.
3. Pilot drill and screw through both sides of 'V' Shaped groove and ensure screw heads are fully sunk into the wood **(Screws not supplied)**.

2. ALUMINIUM TRACK

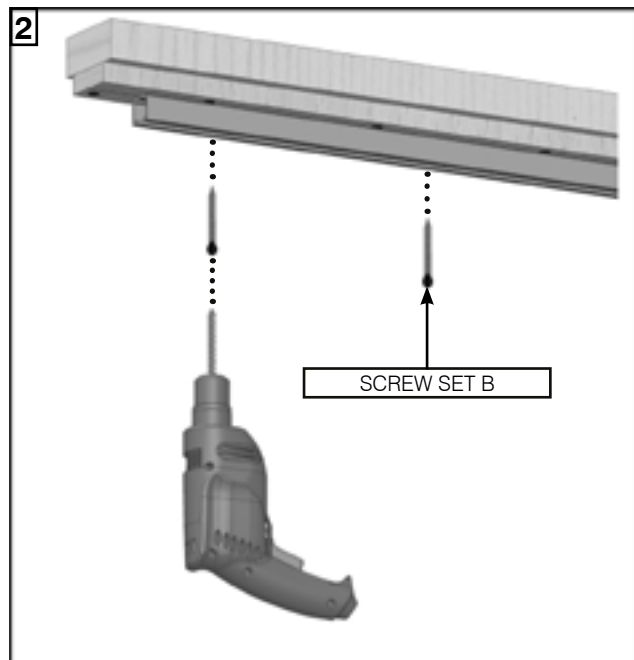
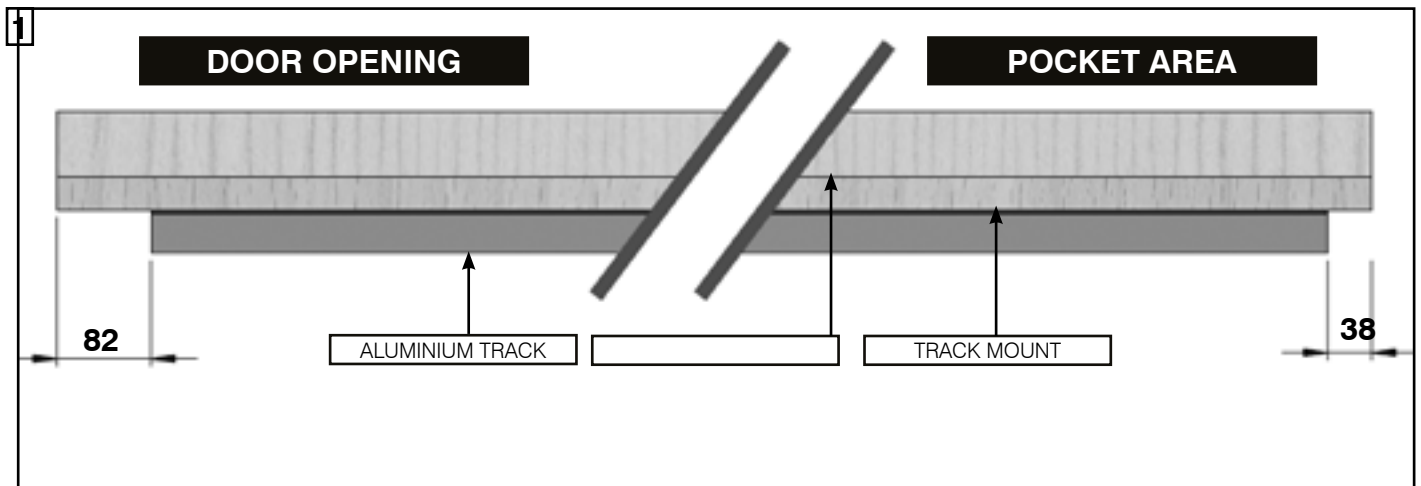

1. For **Single Door Kits**, cut the aluminium track to the width of your horizontal studwork, minus 120mm. Position 82mm in from doorway vertical stud to allow for the end block.
2. Pilot drill through the holes in the track into the 'V' Shaped groove in the plywood track mount. Screwfix using **'Screw Set B'**.

TRACK SHOULD BE WIPED CLEAN TO REMOVE ANY CONTAMINANT

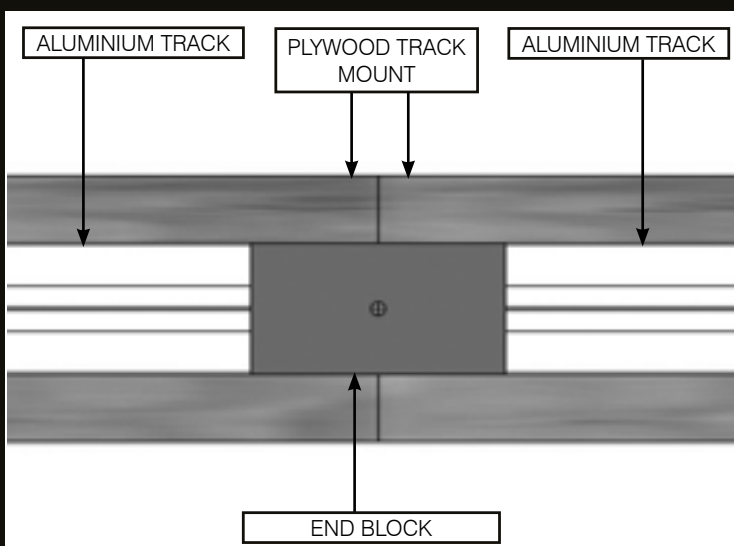

For **Double Door Kits**, cut the aluminium tracks to half the width of your horizontal studwork, minus 70mm.

Position the end block centrally into the plywood track mount and screw into the 'V' shaped groove with **'Screw Set D'**.

Butt the aluminium tracks to it, leaving a gap to the far side of each track and fix into the 'V' shaped groove in the plywood track mount with **'Screw Set B'**.

At this point remove the end block as entry to tracks is required for installation.

3. SOLE PLATE

plusSole Plate may need cutting down depending on door size.
(not supplied)

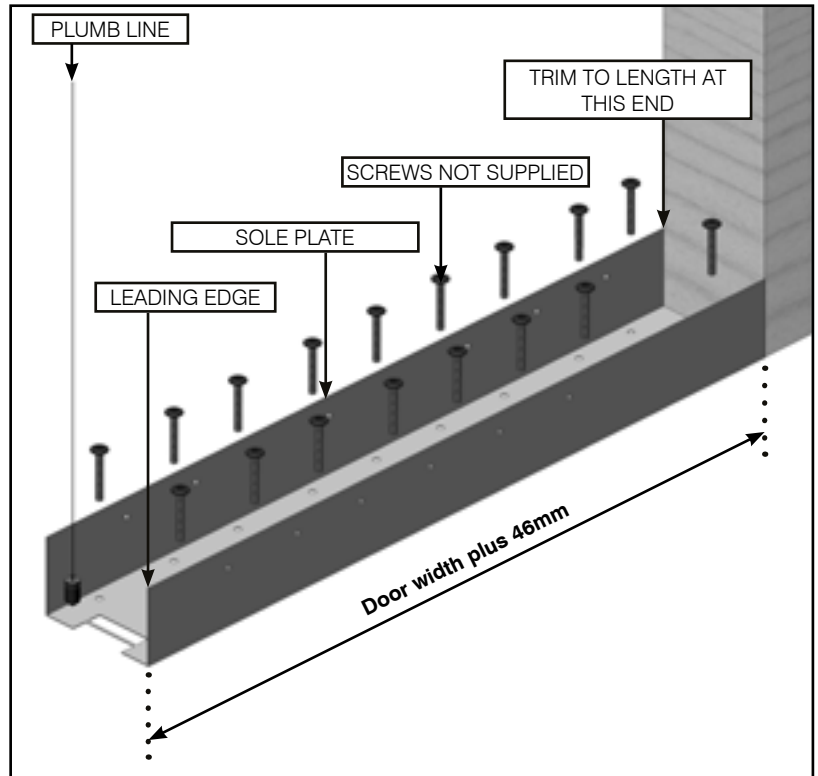

For double kits repeat on other side

4. 'Z' PANELS

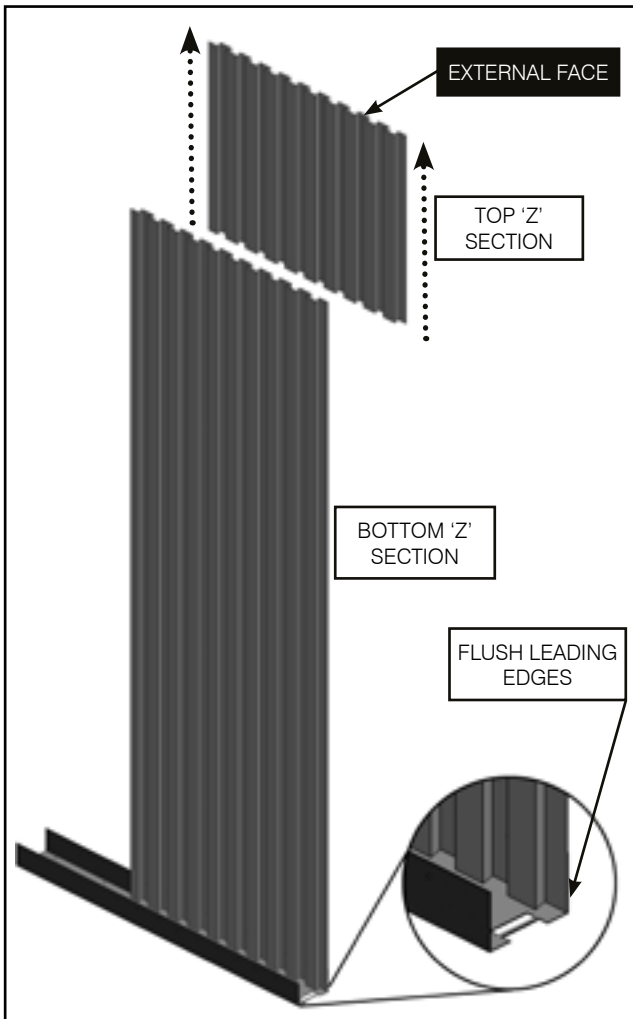

1. Extend the 'Z' Panels to desired height (inside surface of sole plate to underside of top studwork).

DO NOT DISSASSEMBLE 'Z' PANEL SHEETS

2. Position the bottom 'Z' Panel inside the sole plate so that both leading edges are flush.

MAKE SURE THE TOP 'Z' SECTION IS ON THE OUTSIDE OF THE POCKET



IF USING A REINFORCING KIT - PLEASE REFER TO INSTRUCTIONS 003-285 AND INSTALL IT AT THIS POINT BEFORE SCREW FIXING THE 'Z' PANELS

PLEASE NOTE: TOP 'Z' SECTION IS ON THE OUTSIDE OF THE POCKET

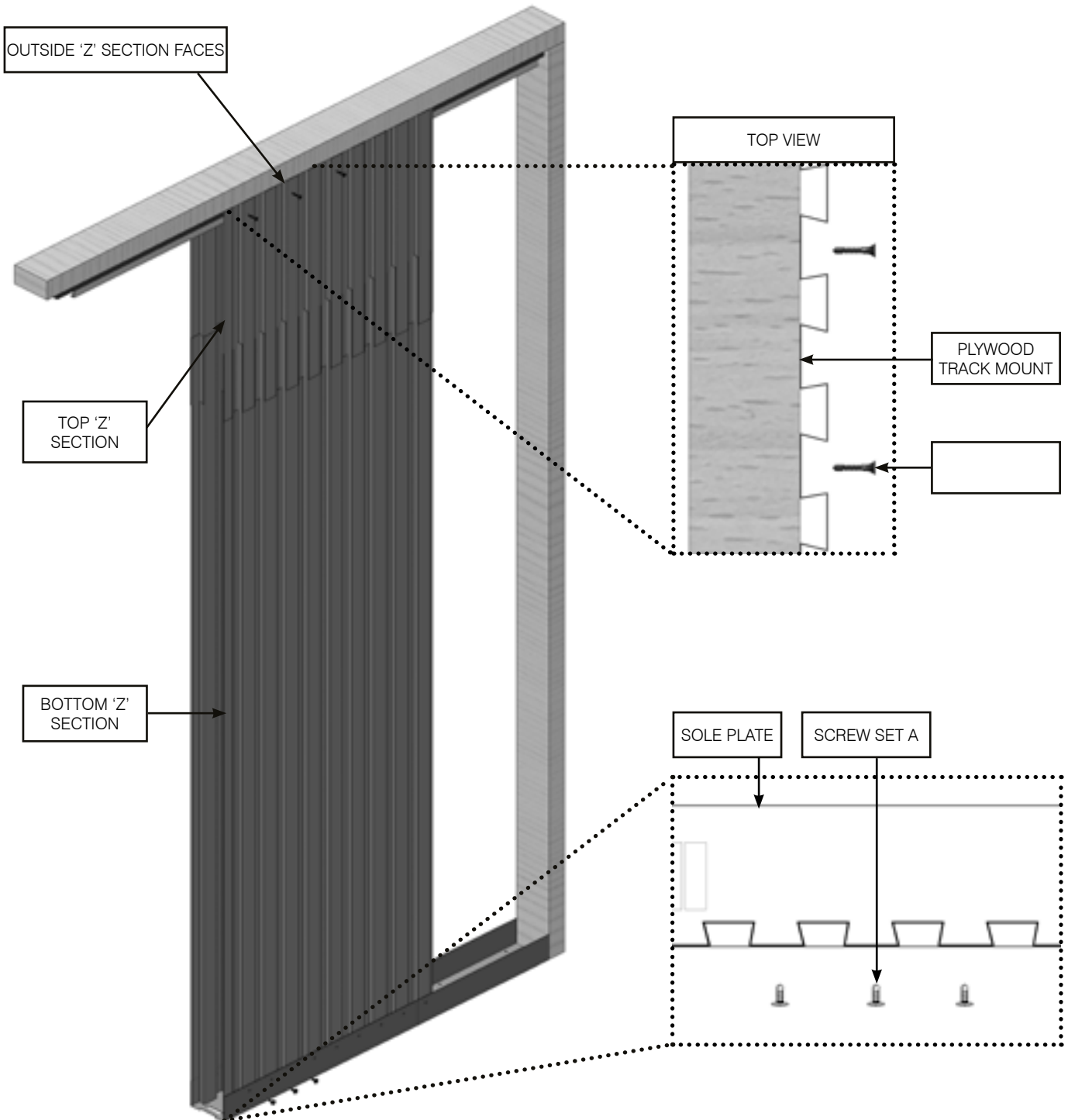

Ensure panels are level and then fix with screws.

1. Fix top 'Z' Section to plywood track mount with '**Screw Set C**'.
2. Fix bottom 'Z' section to sole plate with '**Screw Set A**'.

5. PANEL JOINING

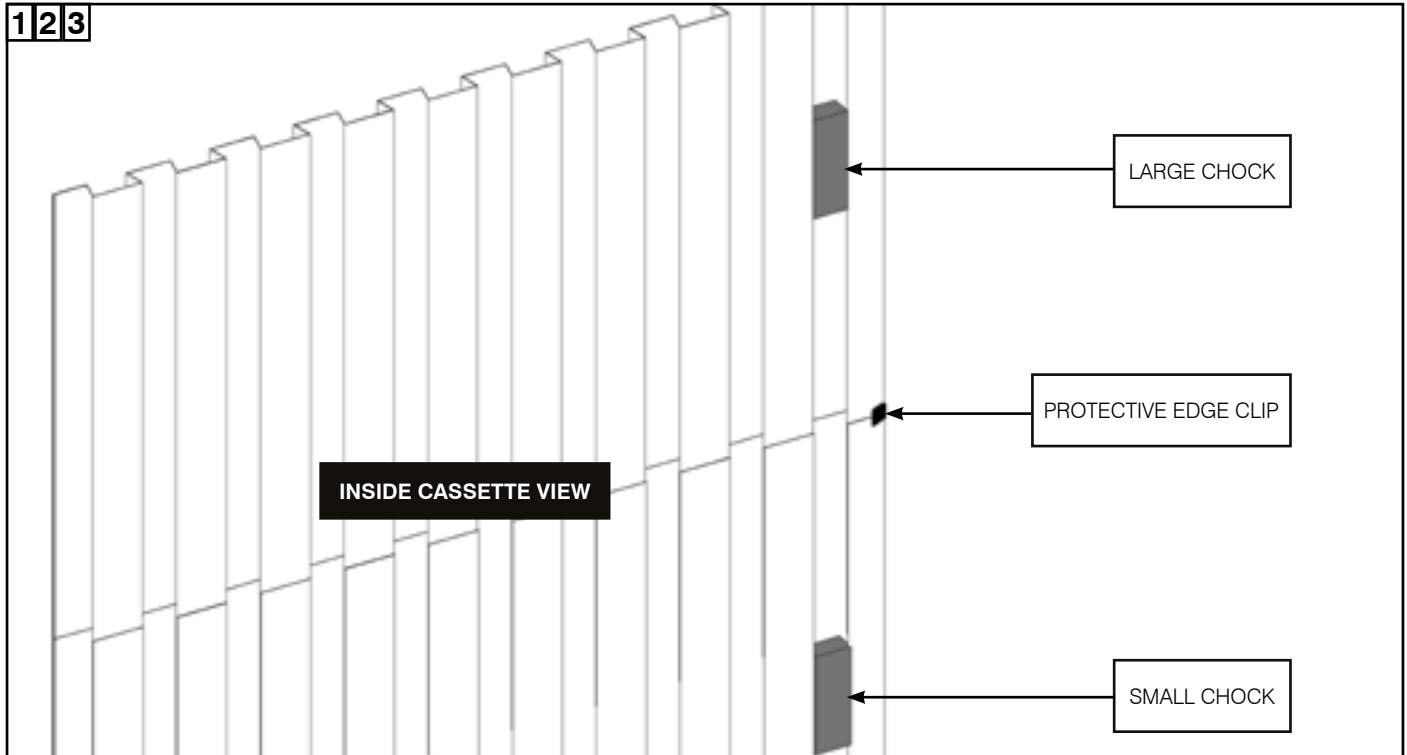

1. At the back of the pocket, place the protective edge clip onto the 'Z' section, covering where the panels join.
2. In the last 'Z' section slot towards the back of the inside pocket, push the large chock into the top 'Z' section and the two small chocks into the bottom 'Z' section. This pushes the edge outwards so the door does not snag on it when closing.

For intermediate and wide kits, fit chocks in the first and last slot in the rear 'Z' sections as detailed above
Fit protective edge clips on all joints on the rear 'Z' sections

3. Repeat stages 4 - 5 on the other side of the pocket.

For double kits repeat stages 4 - 5 to create the second pocket

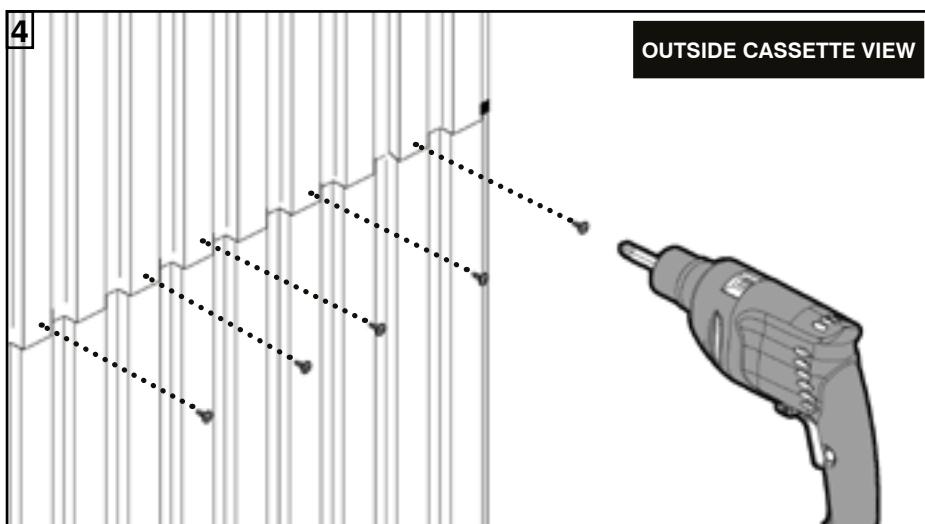

4. Pilot and screw through from outside to join panels together in five locations using 'Screw Set A'

**ENSURE SHEETS
DO NOT BECOME
BOWED WHEN
FIXING INTO PLACE**

6. TROLLEY MOUNTS

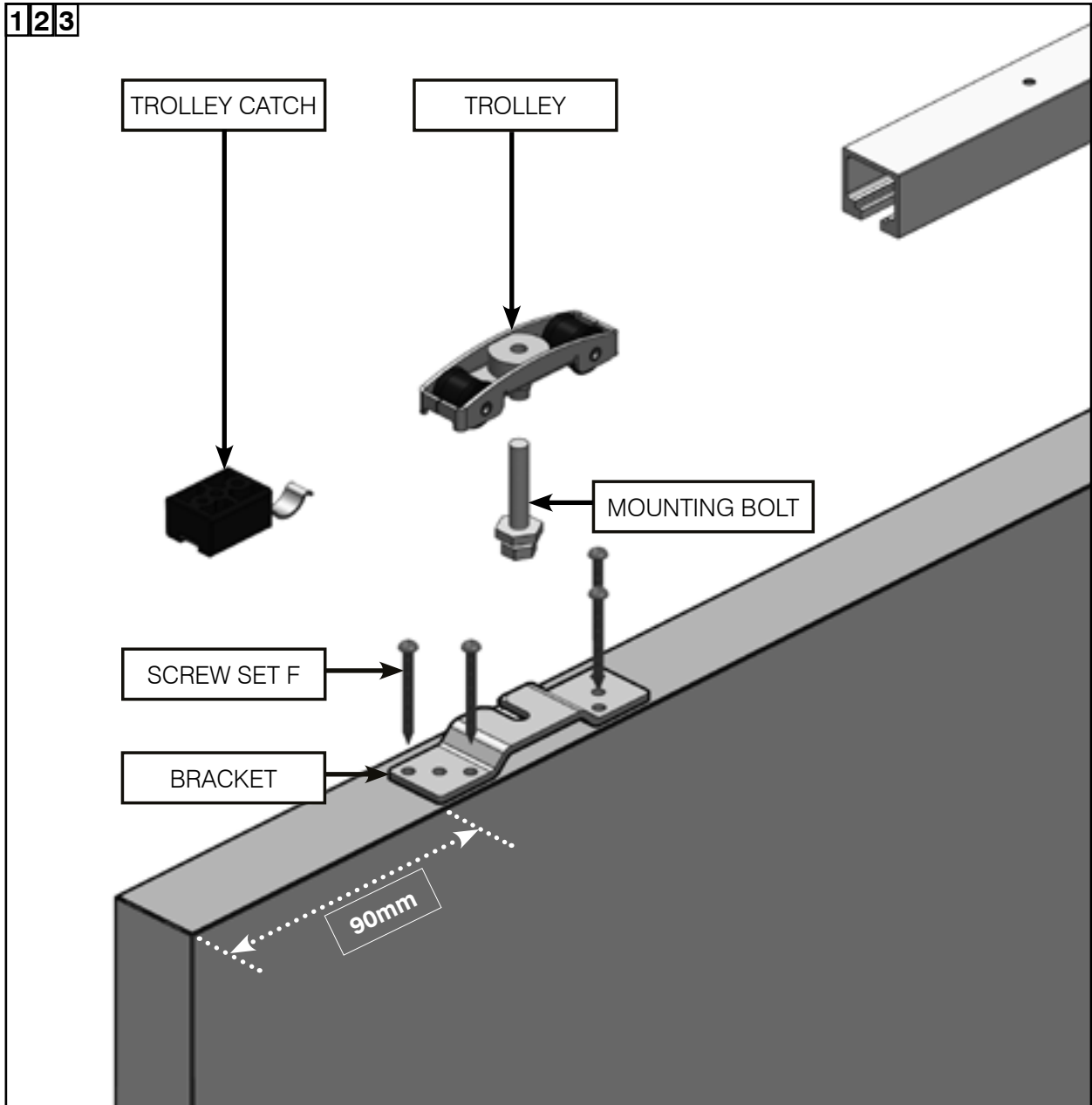

IF USING A TOUCH LATCH - DISCARD THE REAR TROLLEY CATCH

1. Fit the bracket centrally to the top edge of the door using **'Screw Set F'**. Ensure the bracket edge is 90mm away from the door edge. Repeat the procedure for the other bracket.
2. Screw the mounting bolts into the trolleys. Ensure both bolts are screwed in the same amount on both trolleys to ensure the door is level and make adjustment easier.
3. Slide both assembled trolleys into the top rail.
4. Slide both trolley catches into the track, one at the front and one at the back. Do not fix them in place.

For double kits repeat for second door

7. DOOR GUIDE

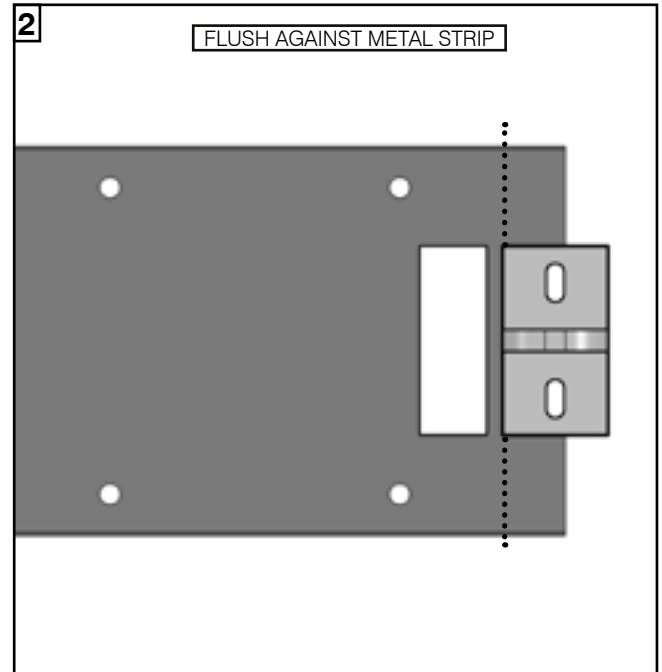
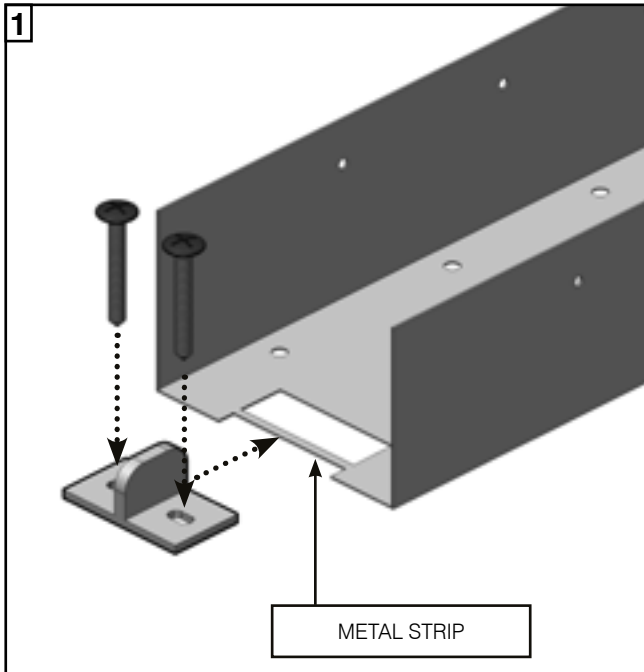

1. Fix the metal floor guide into the sole plate by inserting it into the pre-cut area.
2. Ensure it is flush against the metal strip and then screw fix firmly to the finished floor. **(screws not included)**

For double kits repeat for other side

8. BOTTOM DOOR GROOVE

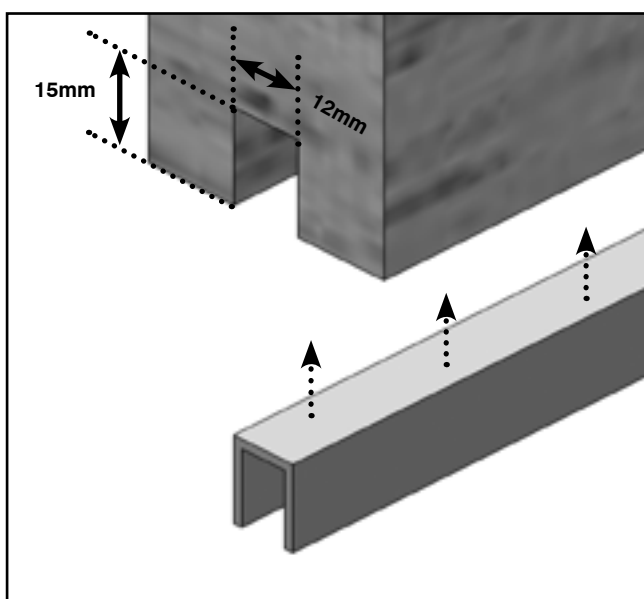

1. Cut a groove in the bottom face of the door to suit the plastic channel which the floor guide runs in.

Ensure when cutting the groove it is centralised along the width of the door.
2. Bond or pin the channel into the cut groove ensuring the metal floor guide can move freely within it. **(fixings not included)**

For double kits repeat for second door

9. DOOR HANGING

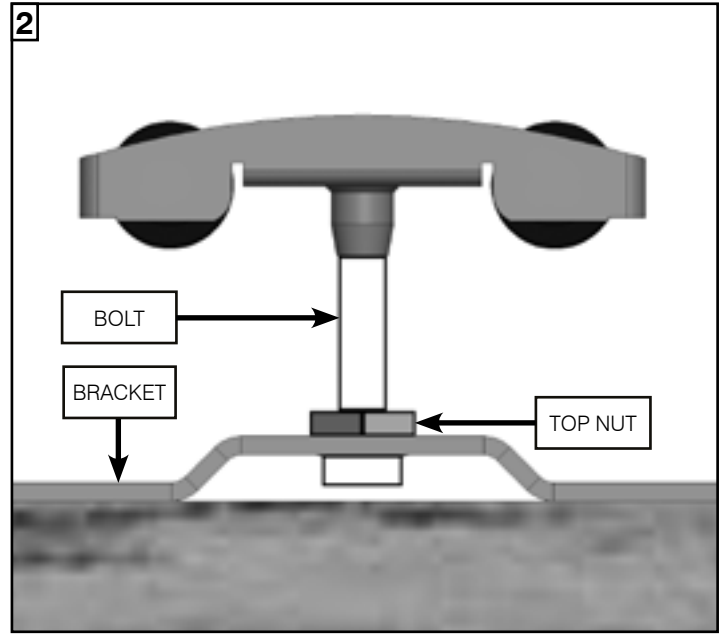
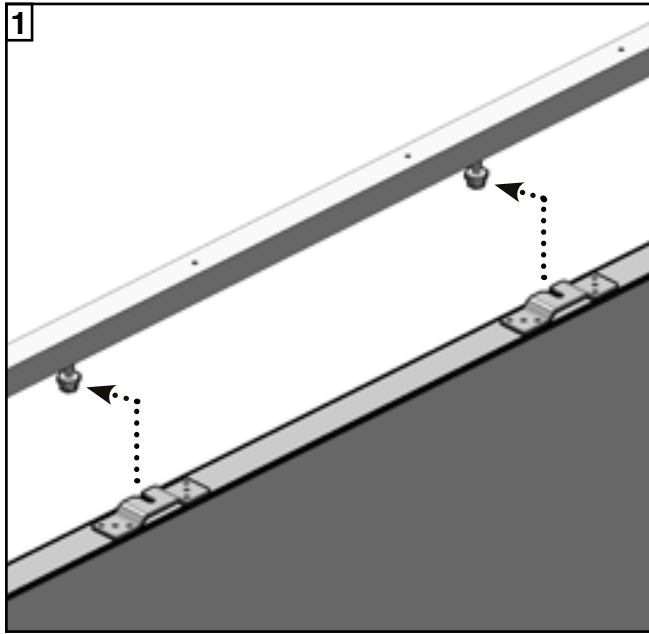

1. Hang the door by sliding the brackets onto the carriage bolts, taking care not to damage the door on the floor guide.
2. Tighten the top nuts onto the brackets to fix the trolleys into place.

TEST THAT DOOR RUNS SMOOTHLY AND IS PLUMB

Correct door operation by adjusting the carriage bolt using provided spanners;

Screw the carriage bolt in slightly to raise the door
Unscrew the carriage bolt slightly to lower the door

For double door kits repeat for second door

If fitting a gravity closer it must be installed prior to adding any of the vertical timber jambs or plasterboard wall boards

10. JAMB FITTING - CASSETTE JAMBS

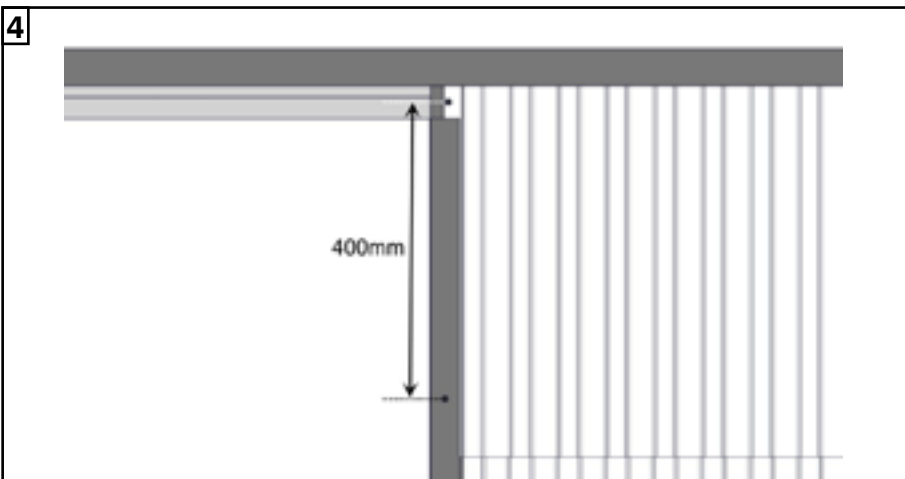
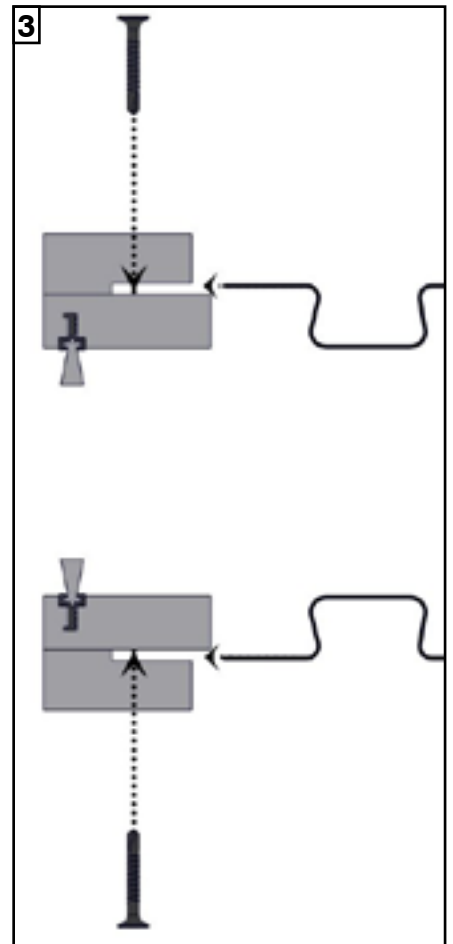
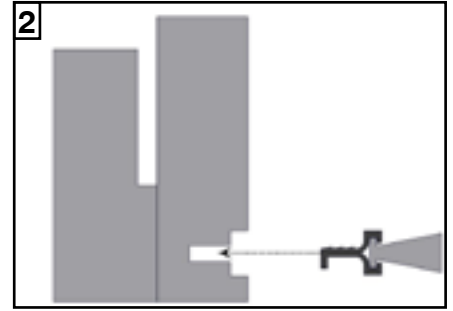
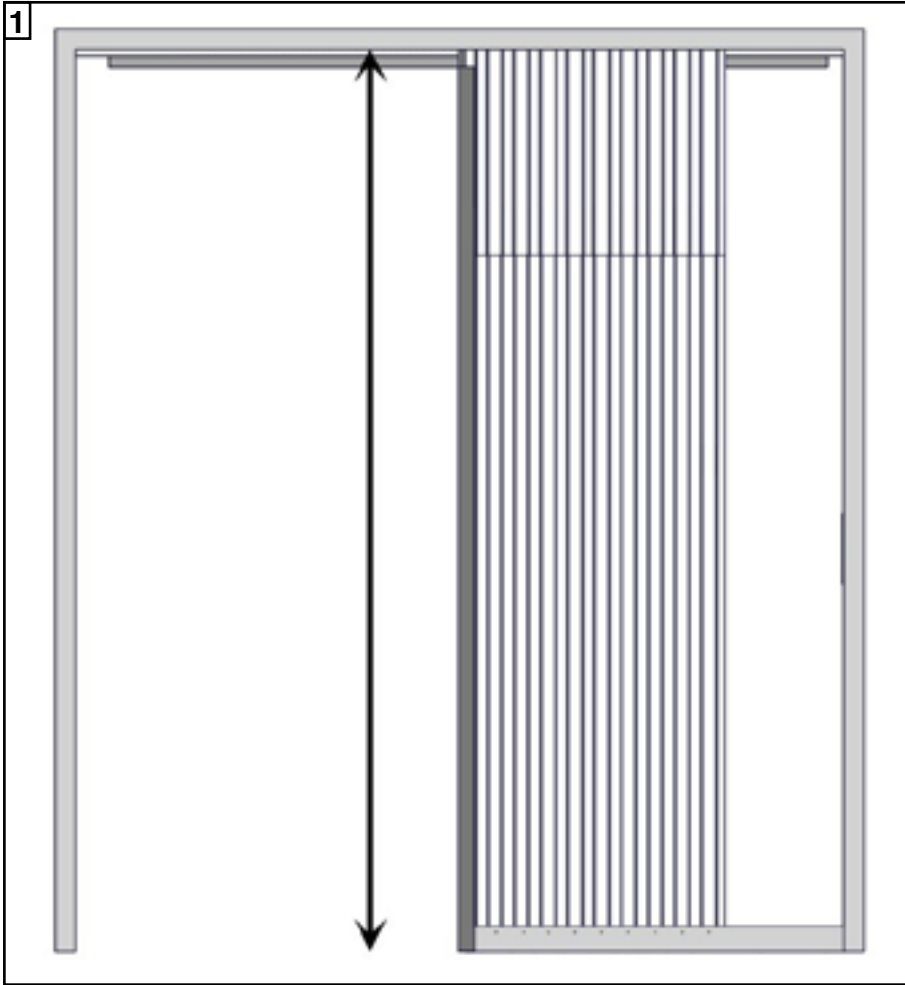

1. Cut cassette jambs to the studwork height from the finished floor to the underside of the stud. Ensure any cut is made at the end without the notch detail.
2. Push fit the brush seals into all cassette jambs.
3. Press the jambs onto the edges of the 'Z' sections and secure with 'Screw Set C'.
4. Screw at the top and bottom and then approximately every 400mm.

11. TRACK PACKERS

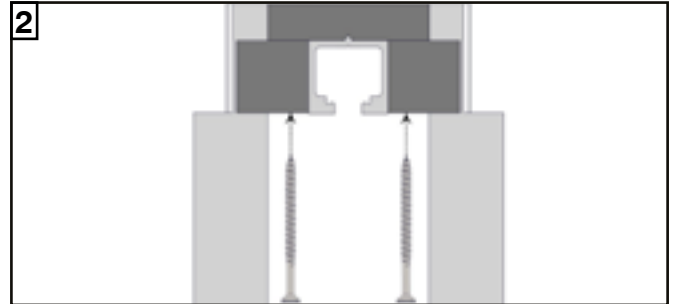
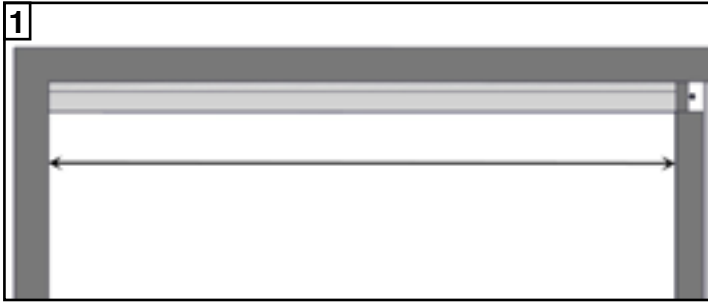

1. To cut the track packers, measure remaining door opening width between the cassette edge jambs and the studwork.

For double kits, measure between the cassette edge jambs of one pocket and the other

2. To secure the track packers, first pilot and countersink a series of holes in their length, approximately 300mm apart. Screw through into the plywood track mount using **'Screw Set E'**.

12. JAMB FITTING - FRONT EDGE JAMB

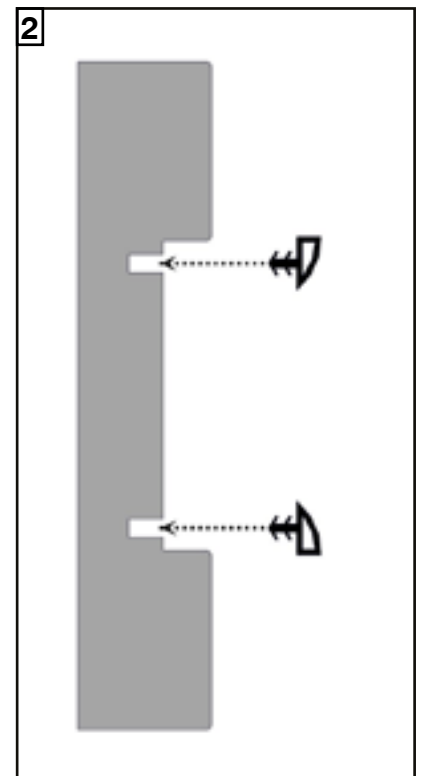
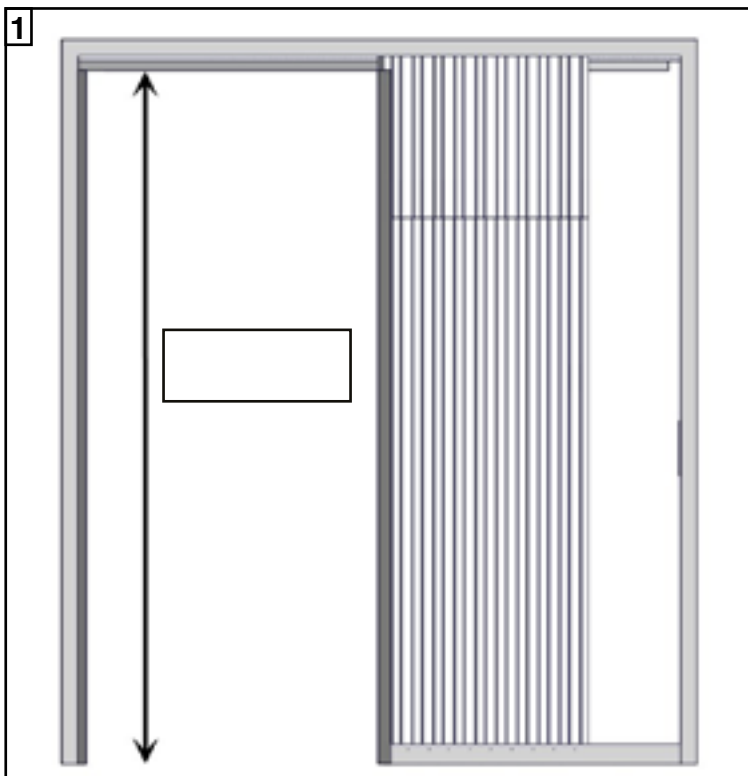

1. Using a sawing or cutting tool, cut the front edge jamb lengths to fit from the the floor to the underside of the track packers. Slide the door to its closed position to test fit. Secure to studwork with appropriate fixings.
2. Cut the rubber seals to the front edge jamb length and press into the pre-made grooves.

For double kits discard this step

13. HEAD SECTION FITTING

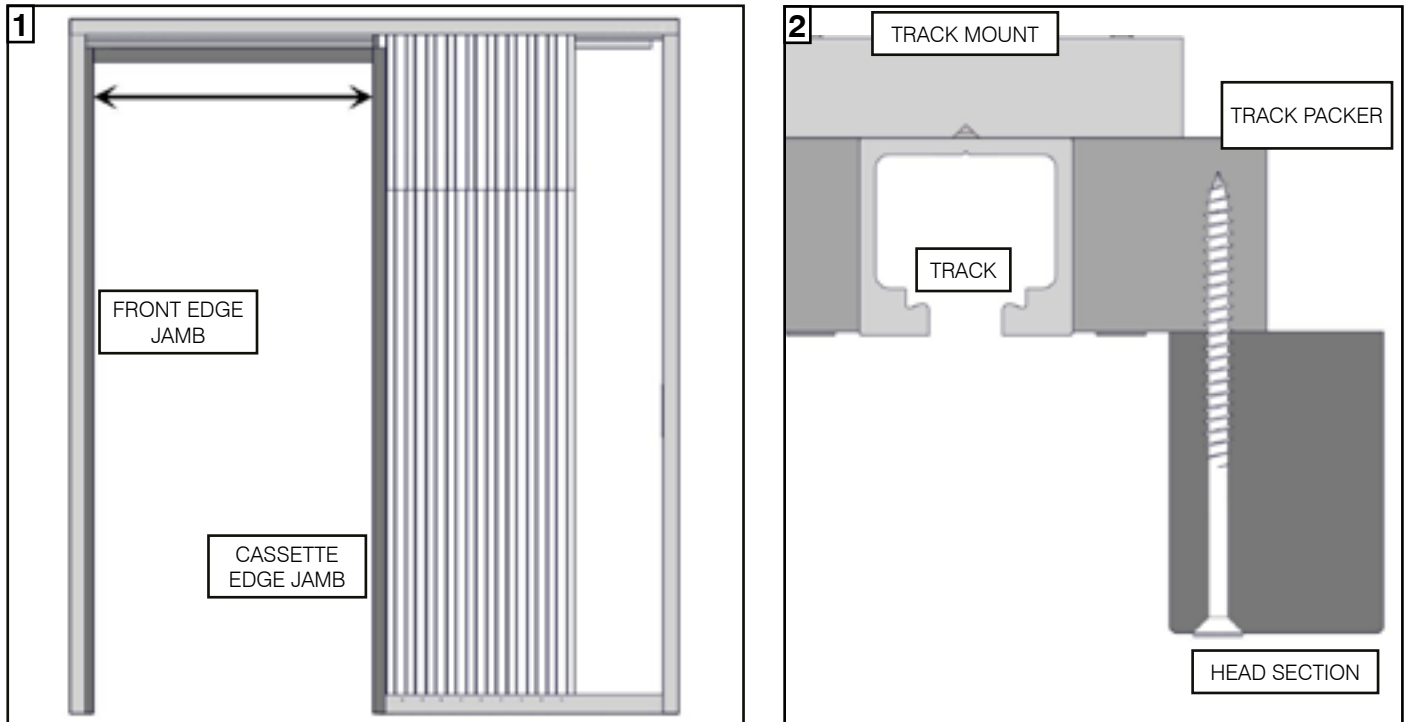

1. Cut the head section to fit between the front edge jamb and the cassette edge jamb.

For double kits, measure between the cassette edge jambs of one pocket and the other

2. A 70mm woodscrew is used to screw through the head section fixing into the track packer, the screws being approximately 300mm apart along the head sections length.

(fixings supplied)

14. DOOR STOPS

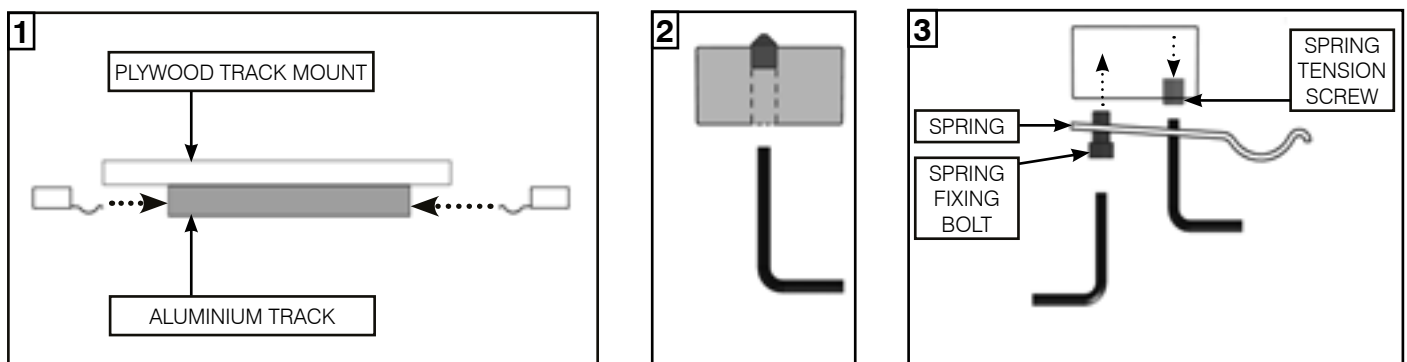

1. Place trolley catches at the front and back of the aluminium track (If not done already).
2. Fix trolley catches in required positions within the aluminium track by removing the spring giving access to the centre hole locking grub screw, use the provided 3mm allen key.
3. Replace the spring and adjust the clamping bolt to the desired tension to hold the trollies in place, use the provided 4mm allen key.

For double kits repeat for second track

INTERMEDIATE AND WIDE KITS

Fit the second set of 'Z' section sheets so that the rear edge is inline with the back of the pocket.

15. END BLOCK

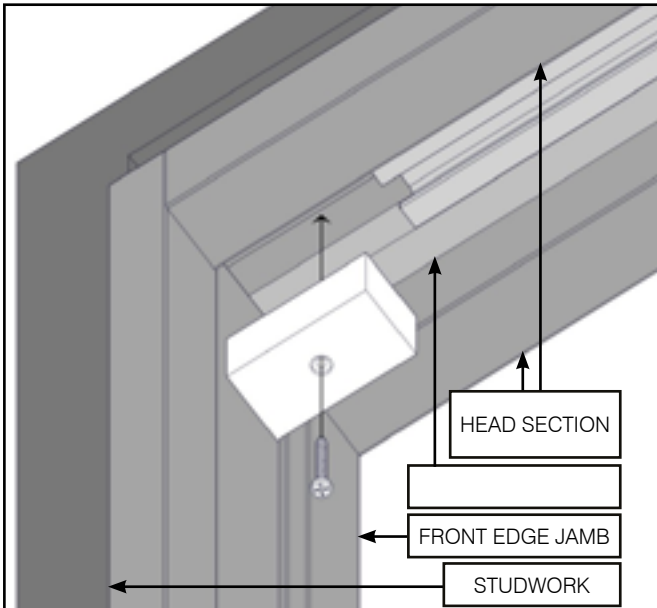

1. Pilot drill and counterbore a hole in the wooden end block using a 2mm drill bit. Drill the hole in the centre of the block.
2. Using the newly made hole, with '**Screw Set D**', screw into the 82mm spacing left between the aluminium track and the studwork. Make sure the end block is butted against the track.

For double kits replace end block into central space

16. PLASTERBOARD

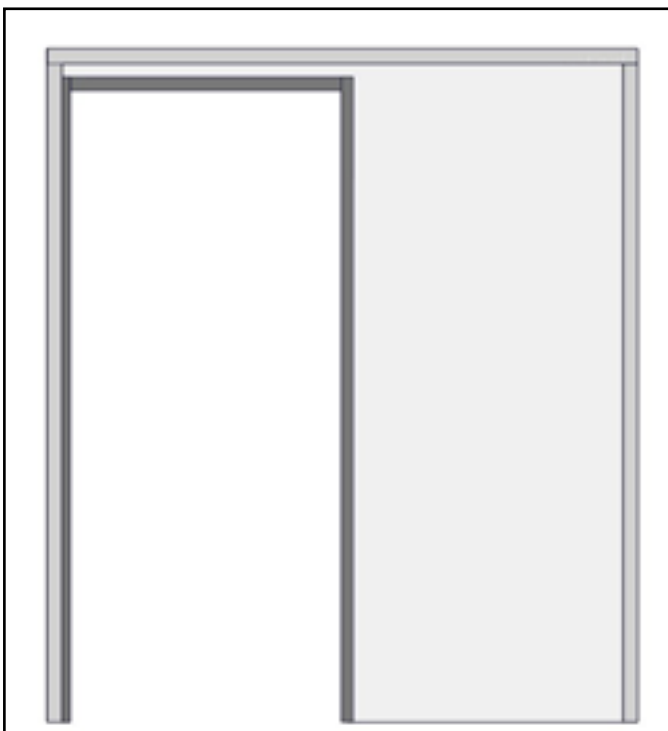

1. Clad the kit in 12.5mm of plasterboard. Ensure it butts up level and tight against all jambs.

When positioned correctly, use screw fixings to secure to the stud frame.
2. Pilot drill through the plasterboard and 'Z' section sheets a maximum of 300mm apart vertically and horizontally equal.

Screw the plasterboard into place.
(fixings not included)

ENSURE NO SCREWS PROTRUDE INTO THE POCKET CAVITY