

P7401 Telescopic Kit FITTING INSTRUCTIONS

For use with 44mm thick doors only
For Single doors

**IF INSTALLING A TOUCH LATCH, PLEASE READ THE
CORRESPONDING FITTING INSTRUCTIONS FIRST**

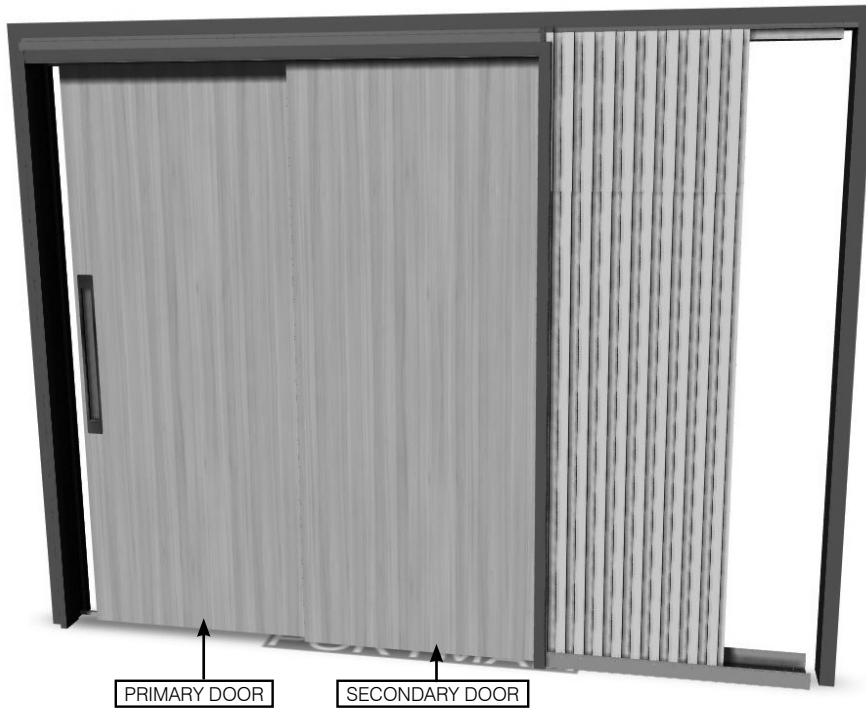

(Image for reference only)

COMPONENTS

POCKET DOOR KIT

- SHORT / LONG 'Z' SECTION
- LONG 'Z' SECTION
- TRACK PACKERS
- PLYWOOD TRACK MOUNT
- ALUMINIUM TRACK
- DOOR BOTTOM CHANNEL
- SOLE PLATE
- RUBBER SEAL
- BRUSH SEAL

FIXING ITEMS

- END BLOCK
- PROTECTIVE EDGE CLIP
- CHOCK LARGE
- CHOCK SMALL
- SCREW SET A
- SCREW SET B
- SCREW SET C
- SCREW SET D
- SCREW SET E
- SCREW SET F

DOOR JAMB SET

- HEAD SECTION
- FRONT EDGE JAMB
- CASSETTE EDGE JAMB

SLIDING MECHANISM

- TROLLEY CATCH
- TROLLEY ASSEMBLY
- FLOOR GUIDE

TOP RAIL COMPONENTS

- ADJUSTABLE PULLEY
- LOWER FLOOR GUIDE
- FIXED BELT CLAMP
- FIXED PULLEY
- MOVING CONNECTOR

SUGGESTED TOOLS



DRILL



G-CLAMP



TAPE MEASURE



HACKSAW



PLUMB LINE



HANDSAW



SPIRIT LEVEL



PROTECTIVE EQUIPMENT

* Quantities are dependant on type of kit ordered

POCKET DOOR KIT

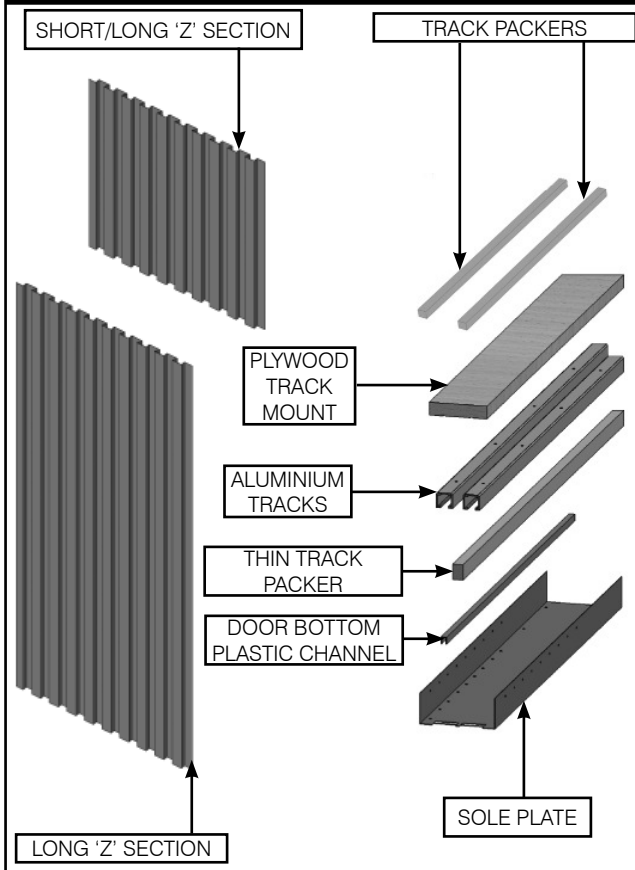

SLIDING MECHANISM

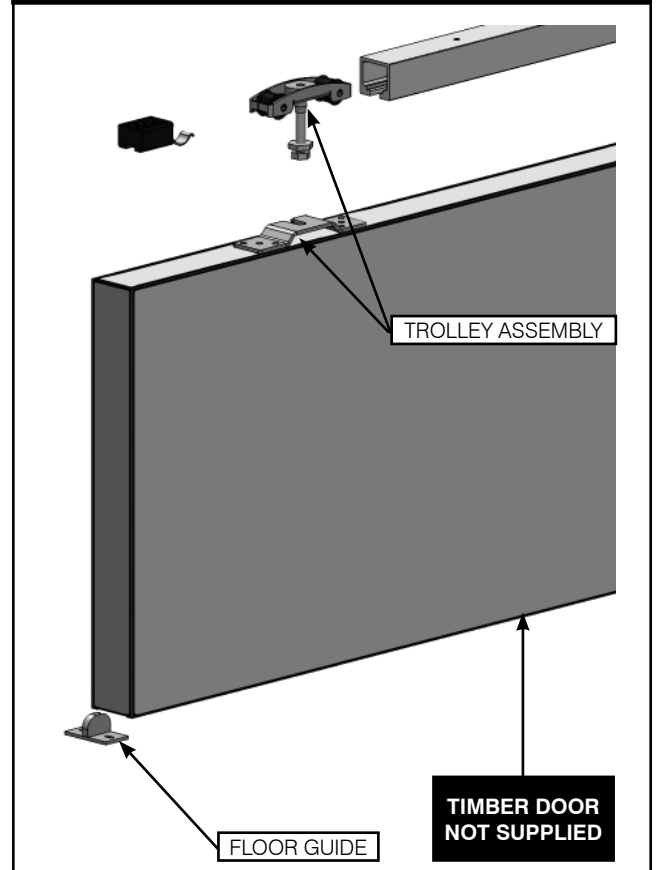

OPTIONAL DOOR JAMB SET

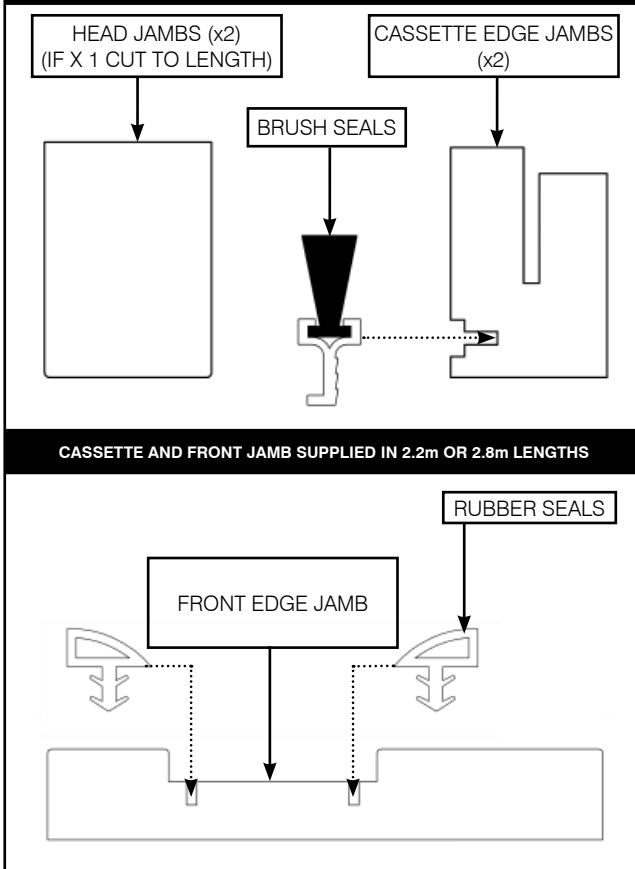

FIXING ITEMS SET

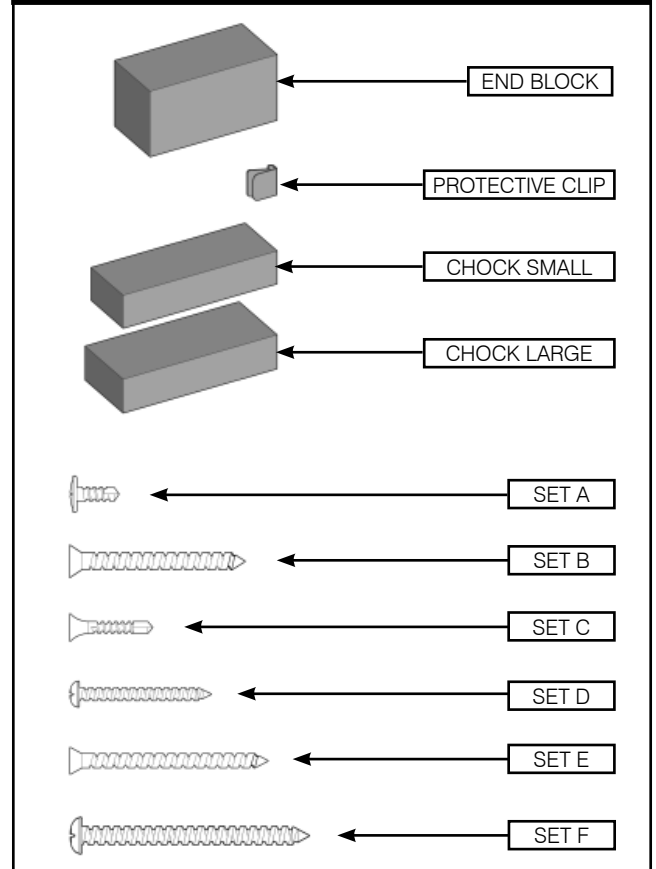

TOP RAIL COMPONENTS

ADJUSTABLE PULLEY

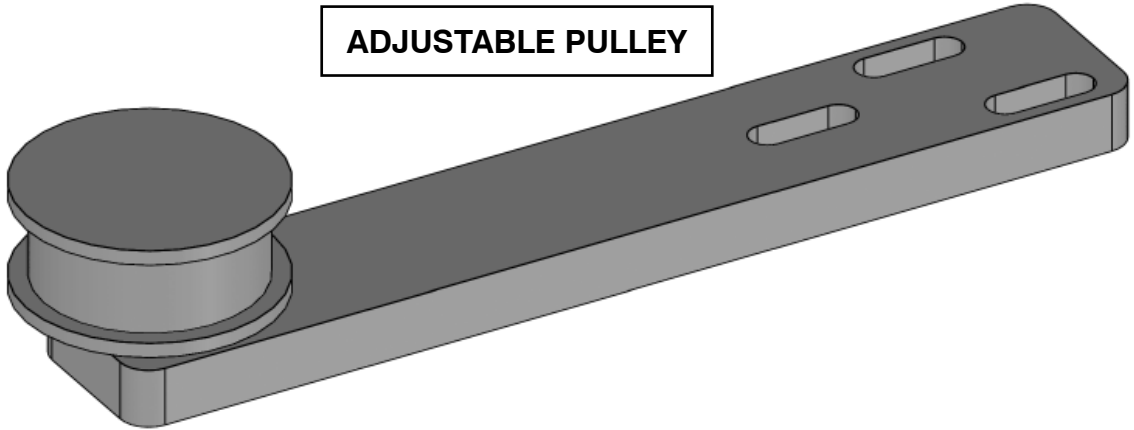

LOWER FLOOR GUIDE

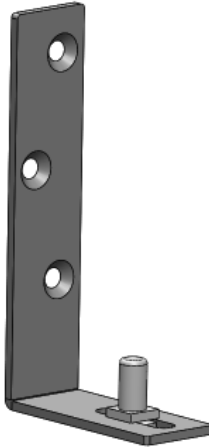

FIXED PULLEY

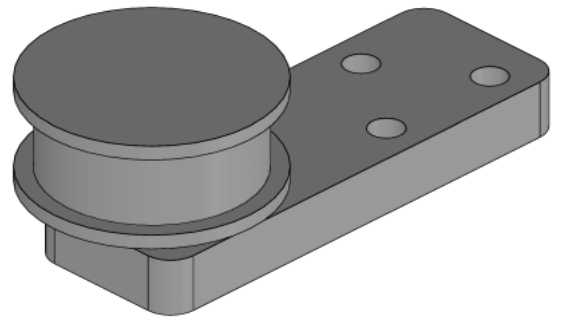

FIXED BELT CLAMP

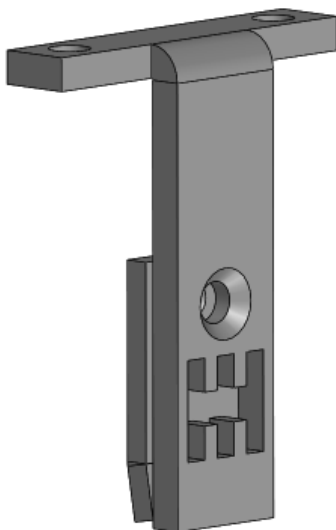

MOVING CONNECTOR

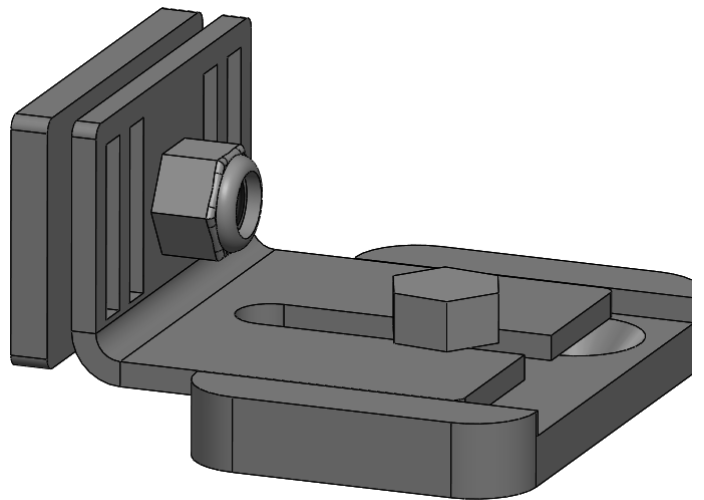

PRE-DOOR FITTING INFORMATION

Firstly construct a studwork frame on which to affix the pocket door system. Portman telescopic doors are designed for 150mm studwork. It is crucial that the frame is constructed square and plumb. Measure door and studwork heights from the finished floor level.

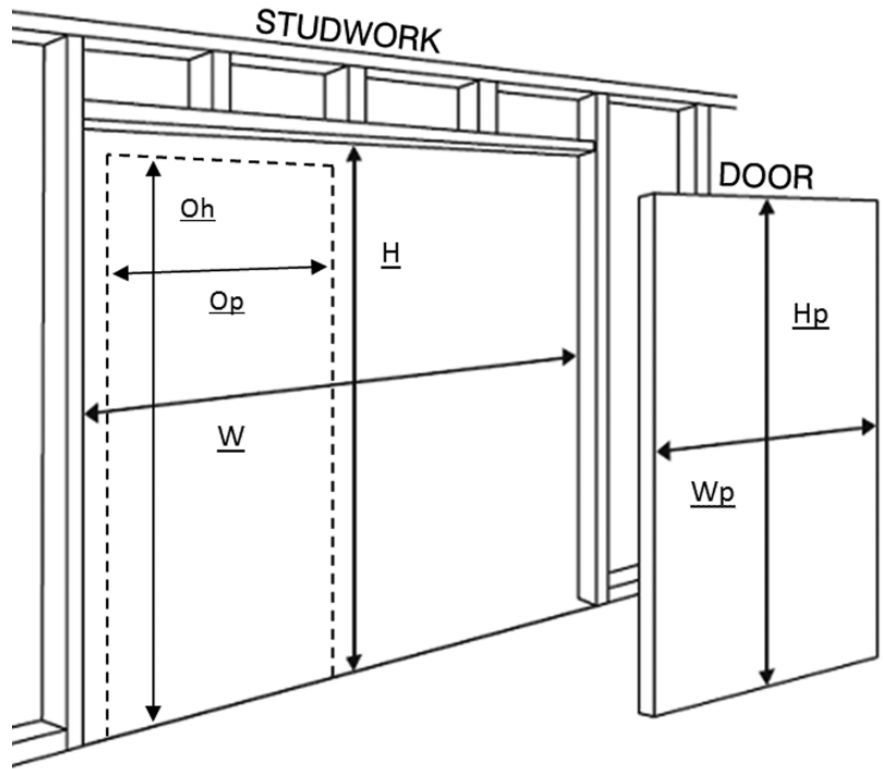

Abbreviations

W = STUDWORK WIDTH

H = STUDWORK HEIGHT

Op = DOOR OPENING WIDTH

Oh = DOOR OPENING HEIGHT

Wp = DOOR WIDTH

Hp = DOOR HEIGHT

1. To calculate **studwork** width and height from known **door dimensions**:

Studwork width (W) = (3 x Door width (Wp)) + 7mm
 Studwork height (H) = Door height (Hp) + 85mm

For double doors: (W) = (6 x (Wp)) - 22mm
 For double doors: (H) = (Hp) + 85mm

2. To calculate **door size** from known **studwork dimensions**:

Door width (Wp) = (Studwork width (W) - 7mm) / 3
 Door height (Hp) = Studwork height (H) - 85mm

For double doors: (Wp) = ((W) + 22mm) / 6
 For double doors: (Hp) = (H) - 85mm

3. To calculate **door size** from known door **opening dimensions**:

Door width (Wp) = Door opening width (Op) + 58mm / 2
 Door height (Hp) = Door opening height (Oh) + 4mm

For double doors: (Wp) = (Op) + 102mm / 4
 For double doors: (Hp) = (Oh) + 4mm

4. To calculate **door opening** width and height from known **door dimensions**:

Door opening width (Op) = 2 x Door width (Wp) - 58mm
 Door opening height (Oh) = Door height (Hp) - 4mm

For double doors: (Op) = (4 x (Wp)) - 102mm
 For double doors: (Oh) = (Hp) - 4mm

1. TRACK MOUNT

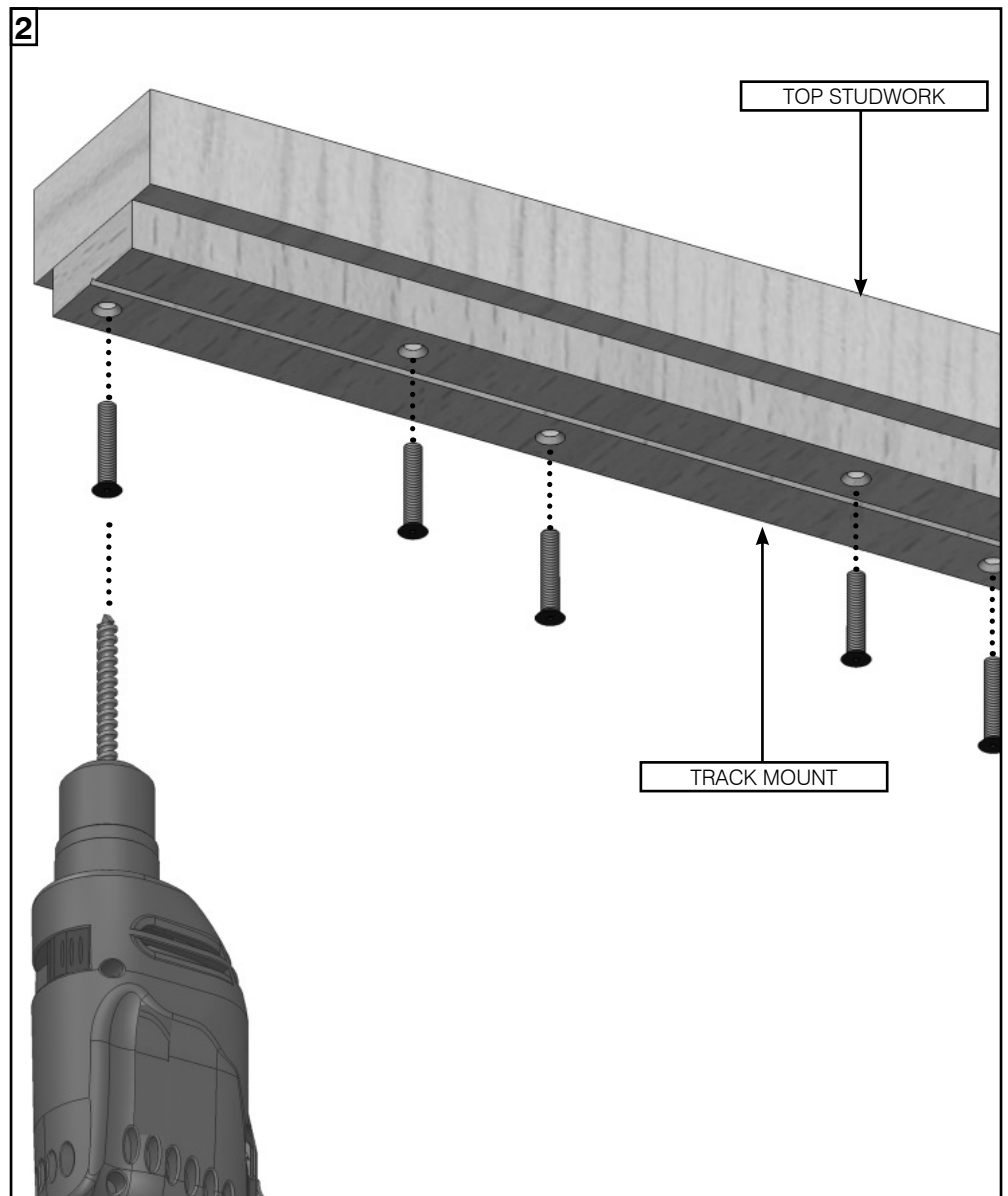
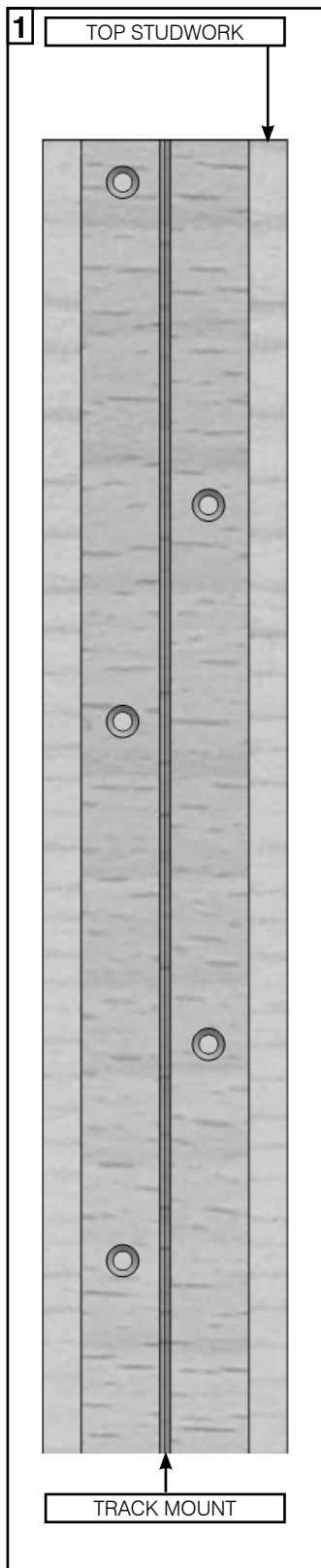

1. Butt the plywood track mounts to the width of your horizontal studwork / support frame. Cut to size as necessary.
2. Position the track mount in the centre of the top horizontal studwork timber / support frame.
3. Pilot drill and screw through both sides of 'V' Shaped groove and ensure screw heads are fully sunk into the wood **(Screws not supplied)**.

2. ALUMINIUM TRACK

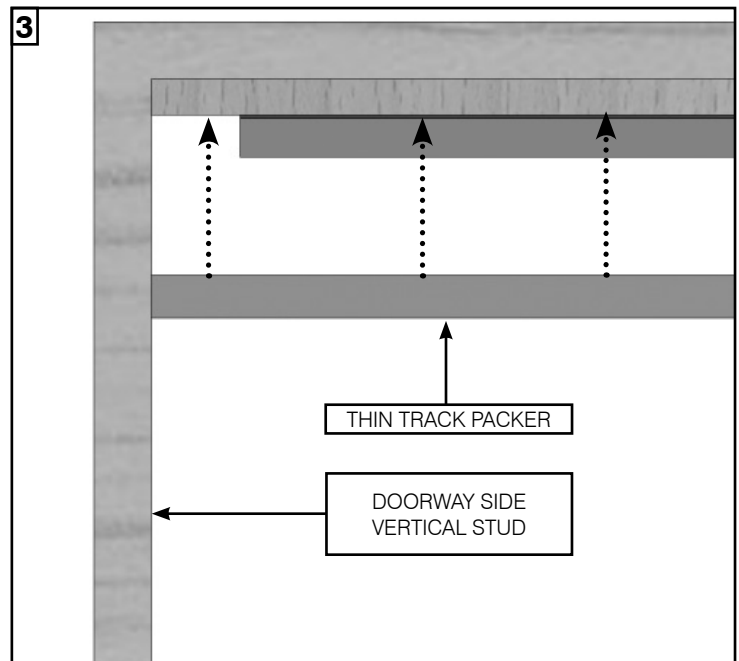
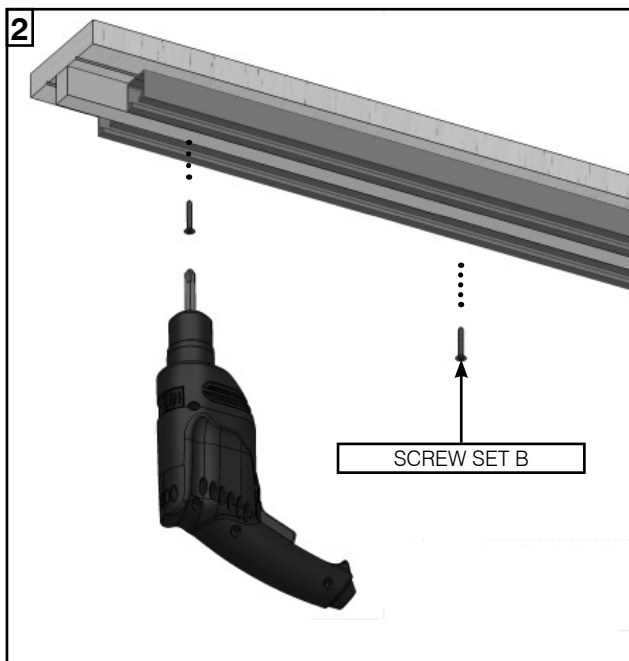
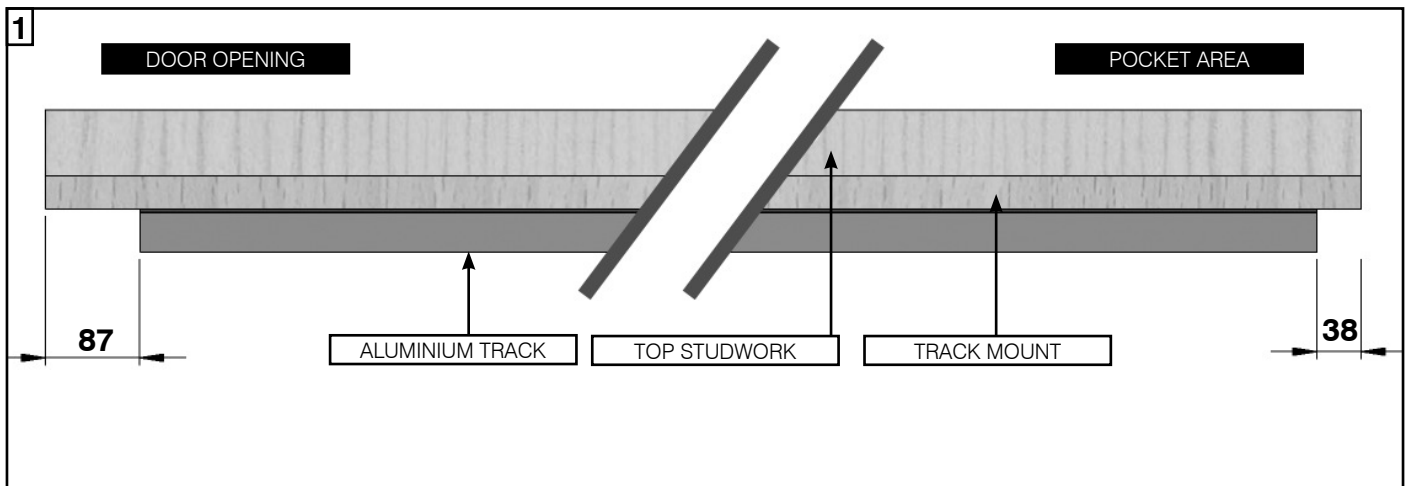

1. Cut the aluminium tracks to the width of your horizontal studwork, minus 125mm. Position 87mm in from doorway vertical stud to allow for the end block.
2. Pilot drill through the holes in the tracks into the 'V' Shaped grooves in the plywood track mount. Screw fix using **'Screw Set B'**.
3. Butt the thin track packer to the doorway side vertical stud in between both top rails and fix to the track mount using screws or pins.
(fixings not included)

TRACK SHOULD BE WIPED CLEAN TO REMOVE ANY CONTAMINANT

3. SOLE PLATE

1. Position the leading edge of the sole plate (Door width plus 22mm) away from the inside face of the rear studwork.

Sole Plate may need cutting down depending on door size.

2. Butt the sole plate centrally to the studwork at the back edge of the pocket.
3. Plumb true to the aluminium track above and secure the plate to the floor with appropriate fixings (**not supplied**).

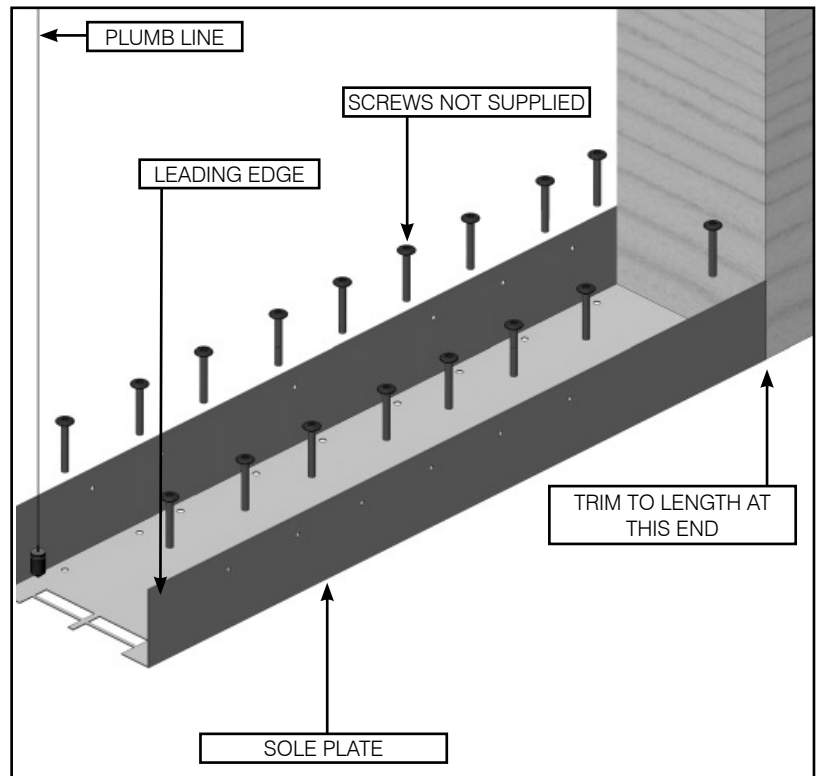

4. 'Z' SECTION PANELS

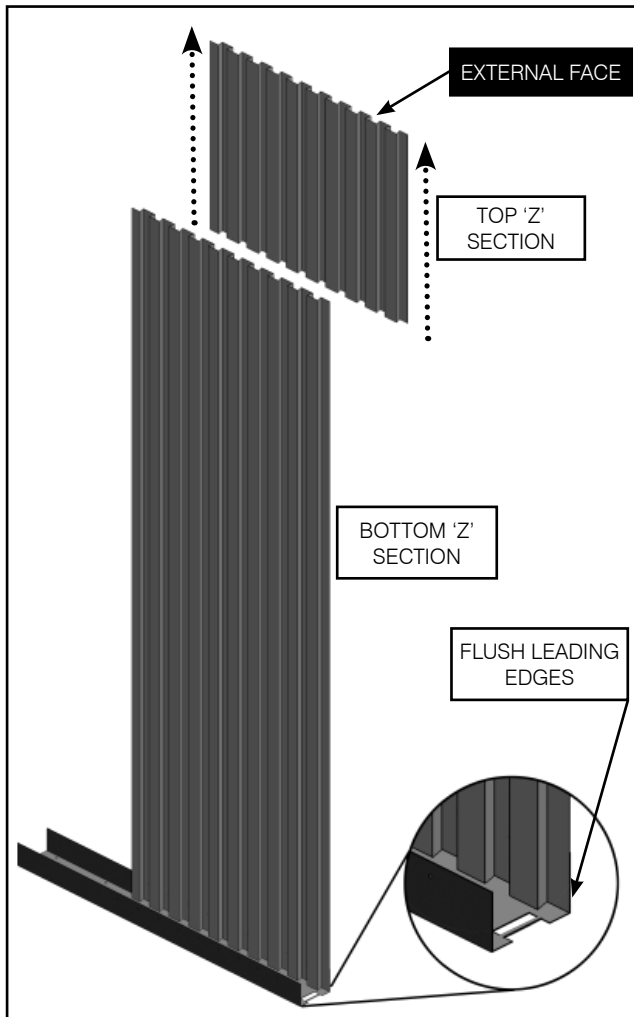

1. Extend the 'Z' sections to desired height (inside surface of sole plate to underside of top studwork).

**DO NOT DISSASSEMBLE
'Z' PANEL SHEETS**

2. Position the bottom 'Z' section inside the sole plate so that both leading edges are flush.

**MAKE SURE THE TOP 'Z' SECTION IS
ON THE OUTSIDE OF THE POCKET**

For intermediate kits a second set of metal 'Z' panels, which are narrower than the first, are supplied.

Fit only the first set at this stage.

IF USING A REINFORCING KIT - PLEASE REFER TO INSTRUCTIONS 003-285 AND INSTALL IT AT THIS POINT BEFORE SCREW FIXING THE 'Z' PANELS

PLEASE NOTE: TOP 'Z' SECTION IS ON THE OUTSIDE OF THE POCKET

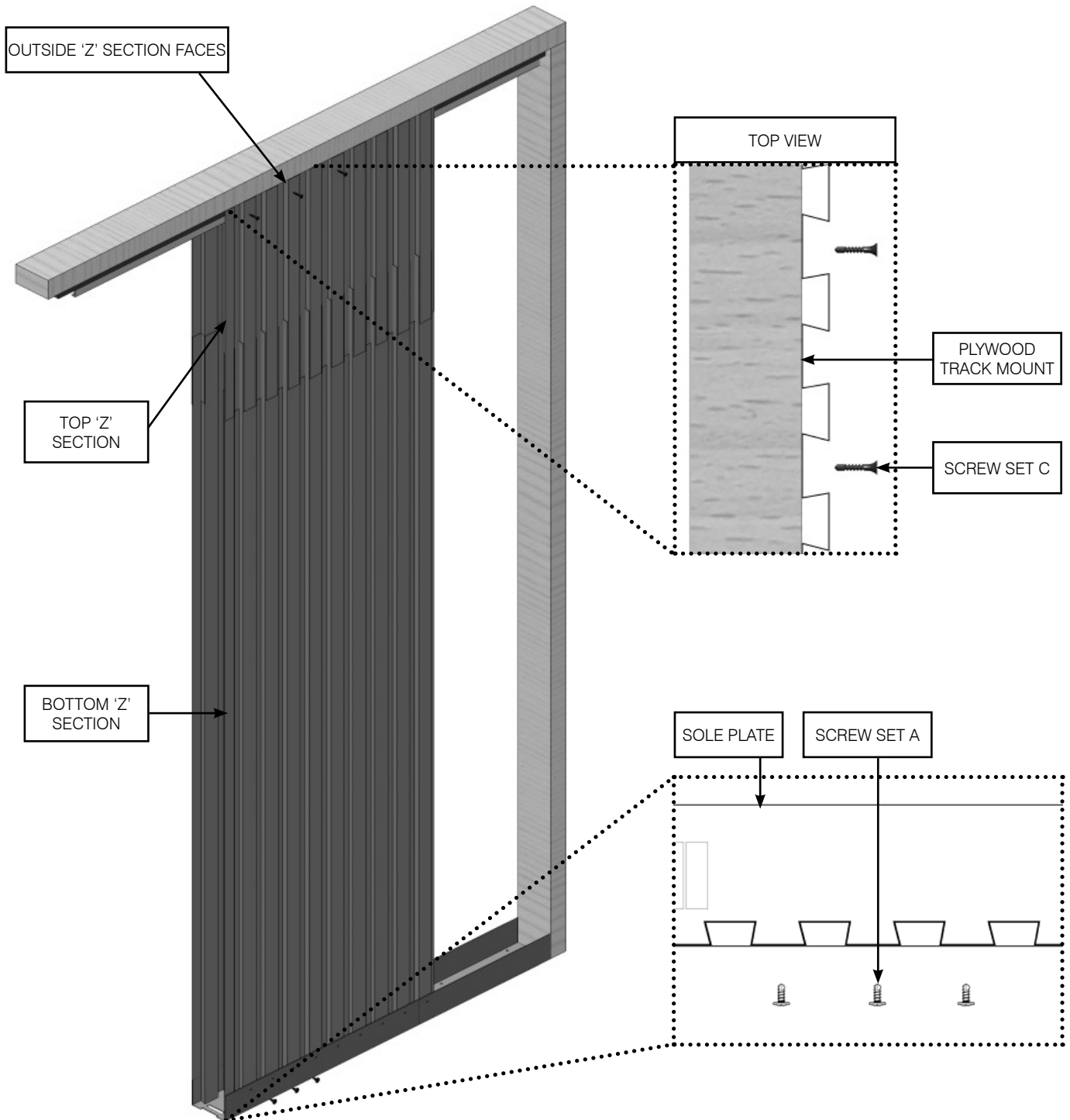

Ensure panels are level and then fix with screws.

1. Fix top 'Z' Section to plywood track mount with **'Screw Set C'**.
2. Fix bottom 'Z' section to sole plate with **'Screw Set A'**.

5. PANEL JOINING

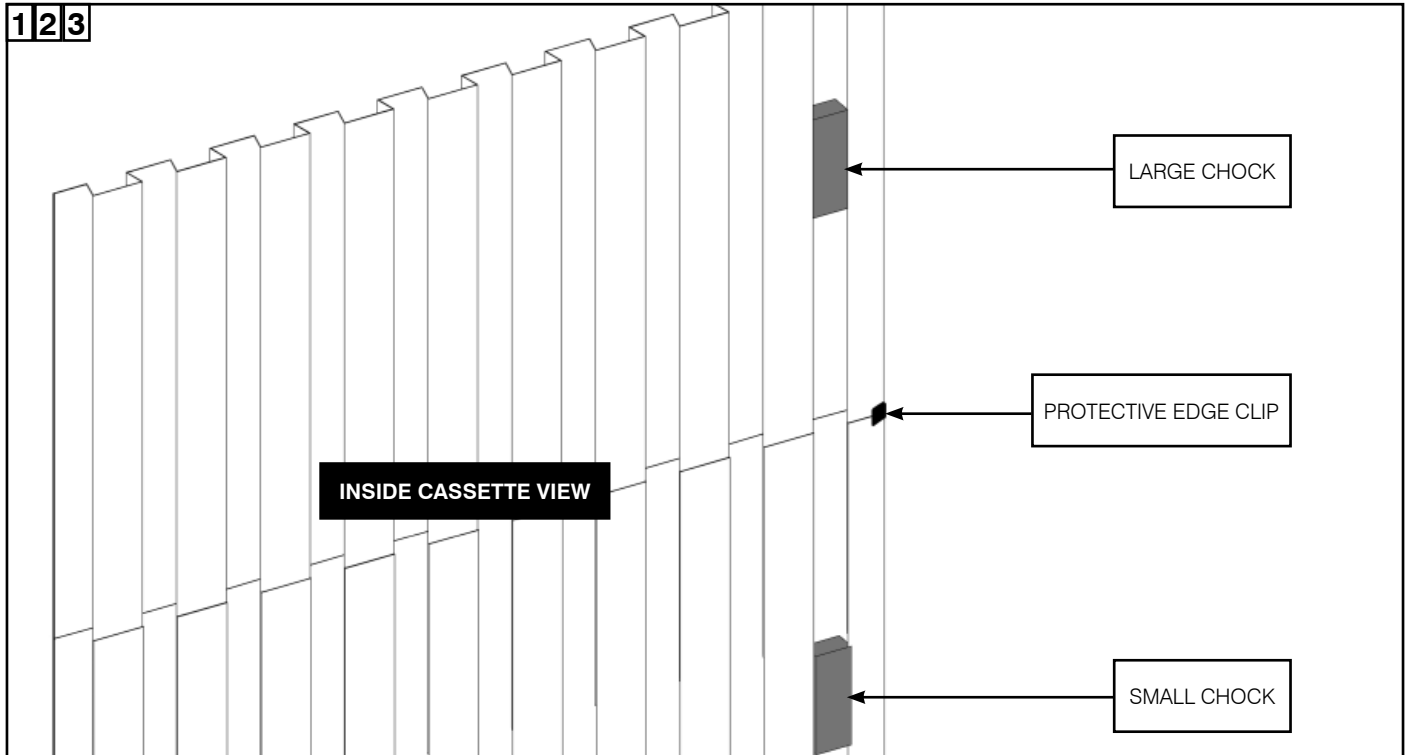

1. At the back of the pocket, place the protective edge clip onto the 'Z' section, covering where the panels join.
2. In the last 'Z' section slot towards the back of the inside pocket, push the large chock into the top 'Z' section and the two small chocks into the bottom 'Z' section. This pushes the edge outwards so the door does not snag on it when closing.

For intermediate kits, fit chocks in the first and last slot in the rear 'Z' sections as detailed above
Fit protective edge clips on all joints on the rear 'Z' sections

3. Repeat stages 4 - 5 on the other side of the pocket.

For double kits repeat stages 4 - 5 to create the second pocket

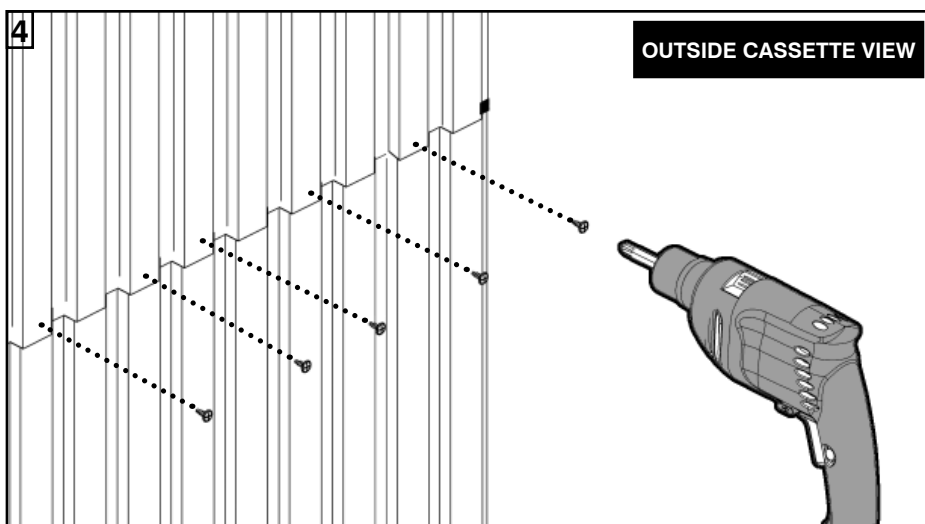

4. Pilot and screw through from outside to join panels together in five locations using 'Screw Set A'

**ENSURE SHEETS
DO NOT BECOME
BOWED WHEN
FIXING INTO PLACE**

6. TROLLEY MOUNTS

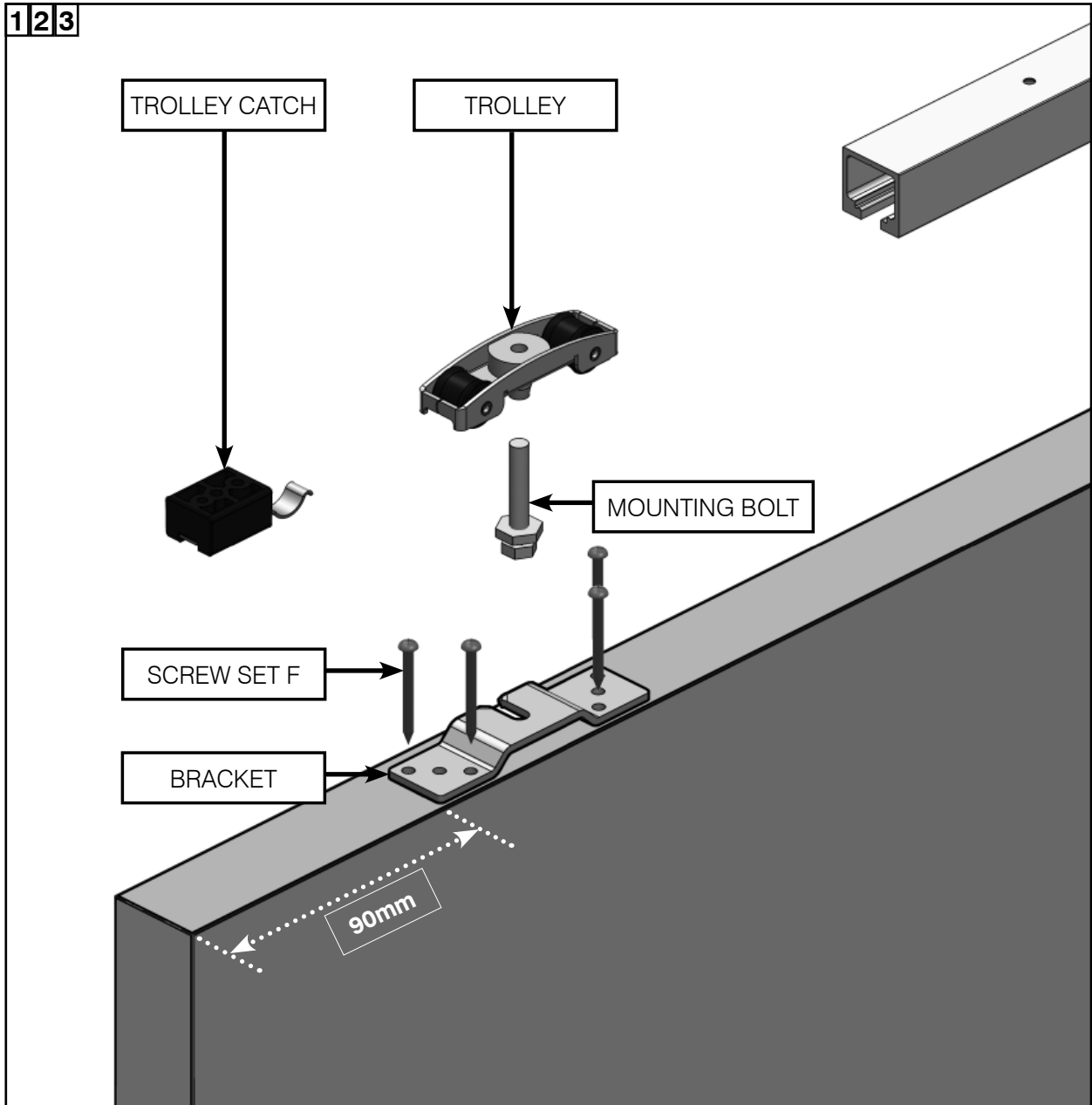

IF USING A TOUCH LATCH - DISCARD THE REAR TROLLEY CATCH

1. Fit the bracket centrally to the top edge of the door using **'Screw Set F'**. Ensure the bracket edge is 90mm away from the door edge. Repeat the procedure for the other bracket.
2. Screw the mounting bolts into the trolleys. Ensure both bolts are screwed in the same amount on both trolleys to ensure the door is level and make adjustment easier.
3. Slide both assembled trolleys into the top rail.
4. Slide both trolley catches into the track, one at the front and one at the back. Do not fix them in place.

For double kits repeat for second door

7. DOOR GUIDE

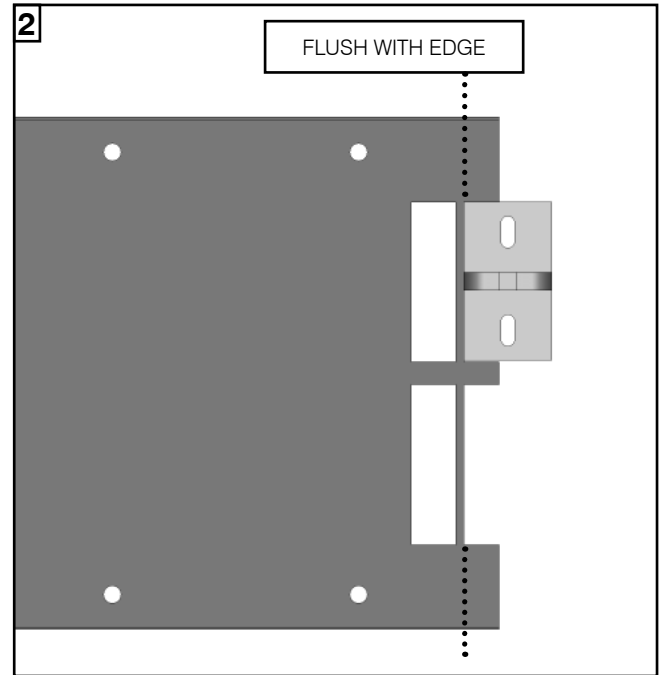
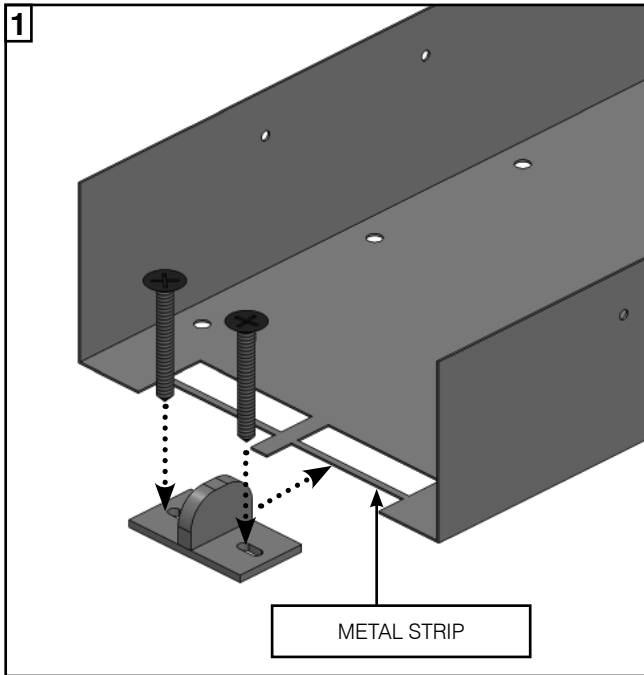

1. Fix the metal floor guide into the sole plate by inserting it into the pre-cut area.
2. Ensure it is flush against the metal strip and then screw fix firmly to the finished floor. **(screws not included)**

8. BOTTOM DOOR GROOVE

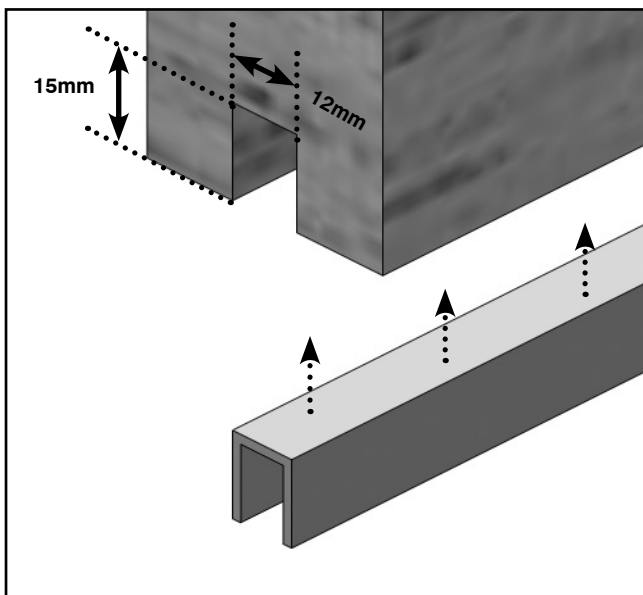

1. Cut a groove in the bottom face of the door to suit the plastic channel which the floor guide runs in.

Ensure when cutting the groove it is centralised along the width of the door.
2. Bond or pin the channel into the cut groove ensuring the metal floor guide can move freely within it. **(fixings not included)**

9. PULLEY FITTING - SECONDARY DOOR

REAR
STUD
WALL

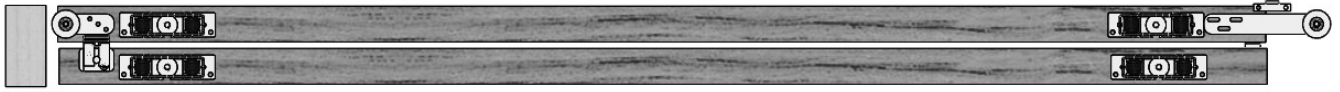

DOOR
LEADING
EDGE

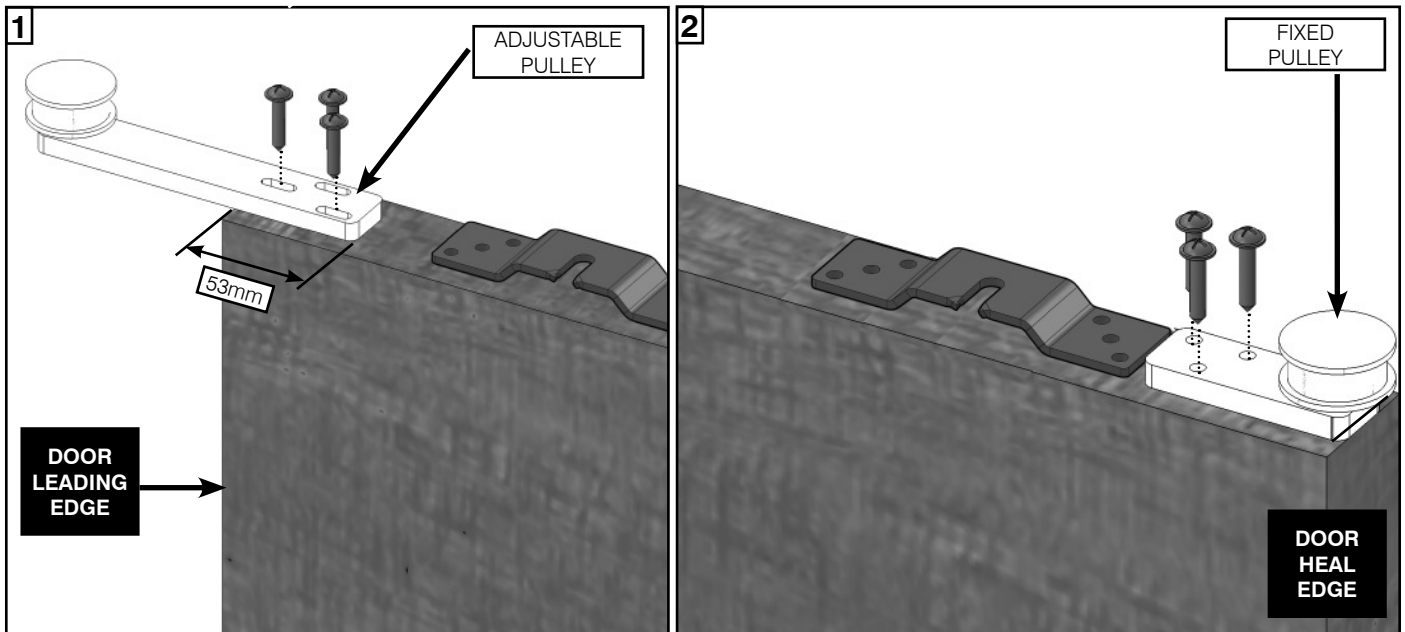

1. Position the adjustable pulley centrally onto the top face of the secondary door, 53mm in from the leading edge. Screw into the door using its supplied fittings.
2. Position the fixed pulley centrally onto the top face of the secondary door. Make sure it is flush with the heel edge of the door. Screw into the door using its supplied fittings.

10. MOVING CONNECTOR - PRIMARY DOOR

1. Nearest the heel edge, position the moving connector flush with the inside face of the primary door. Make sure it is butted up against the door bracket.

Screw into the door using its supplied fittings.

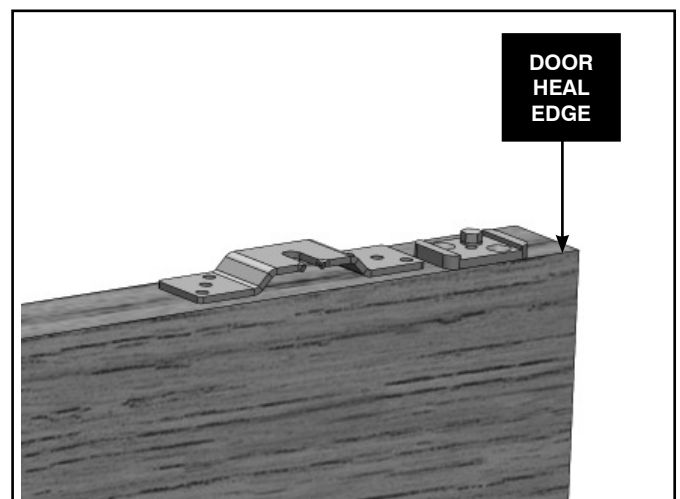

11. LOWER GUIDE - SECONDARY DOOR

1. Position the lower guide 6.5mm in from the leading edge and 4mm down from the bottom of the secondary door. Fix it to the inside face of the door using its supplied fittings.

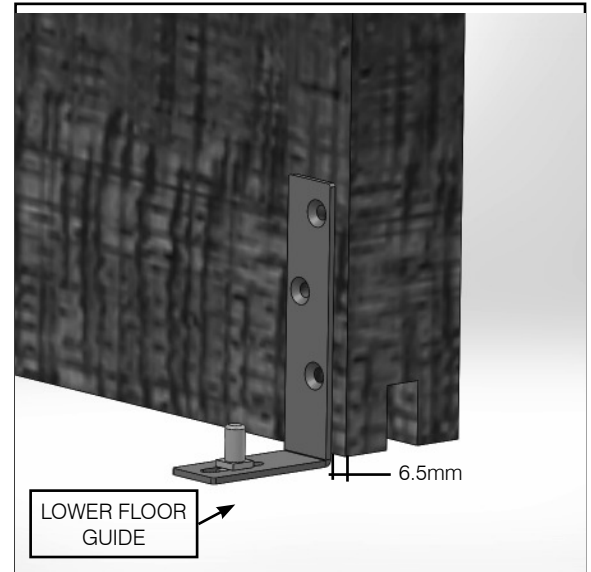
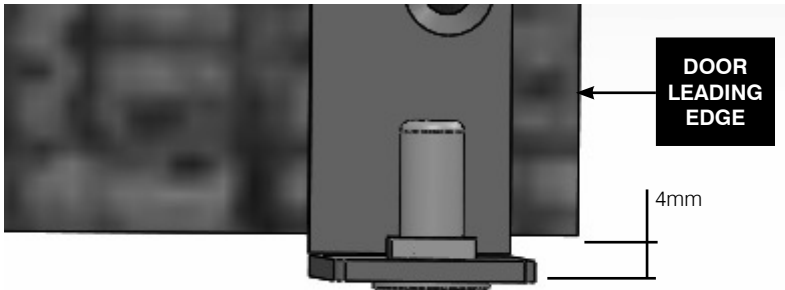

12. COG BELT FITTING - SECONDARY DOOR

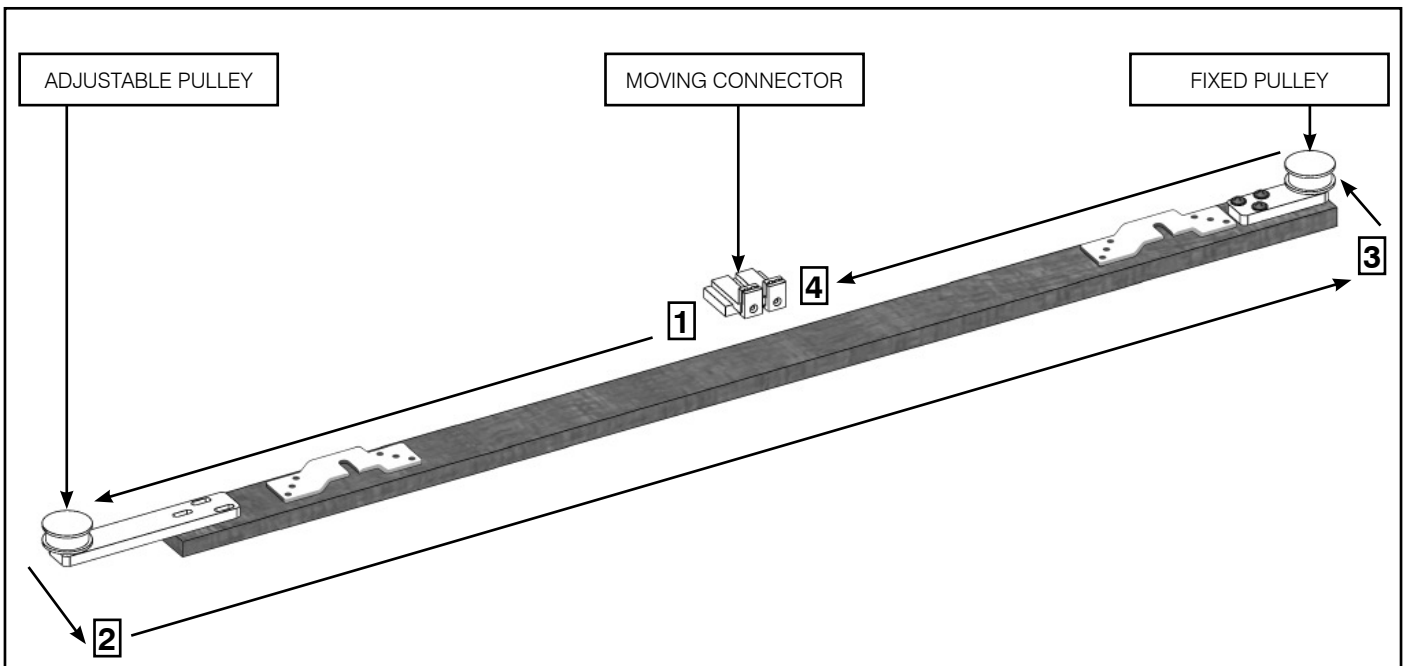

1. Lock one end of the cog belt into the top part of the moving connector.
2. Pass it around the adjustable pulley teeth facing outwards
3. Pass it around the fixed pulley
4. Clamp taught into the other side of the moving connector cutting the belt as required.

PARTIALLY UNSCREW THE ADJUSTABLE PULLEY AND ALTER THE POSITION TO ACHIEVE THE DESIRED BELT TENSION, THEN TIGHTEN SCREWS TO FIX IN PLACE.

13. SECONDARY DOOR HANGING

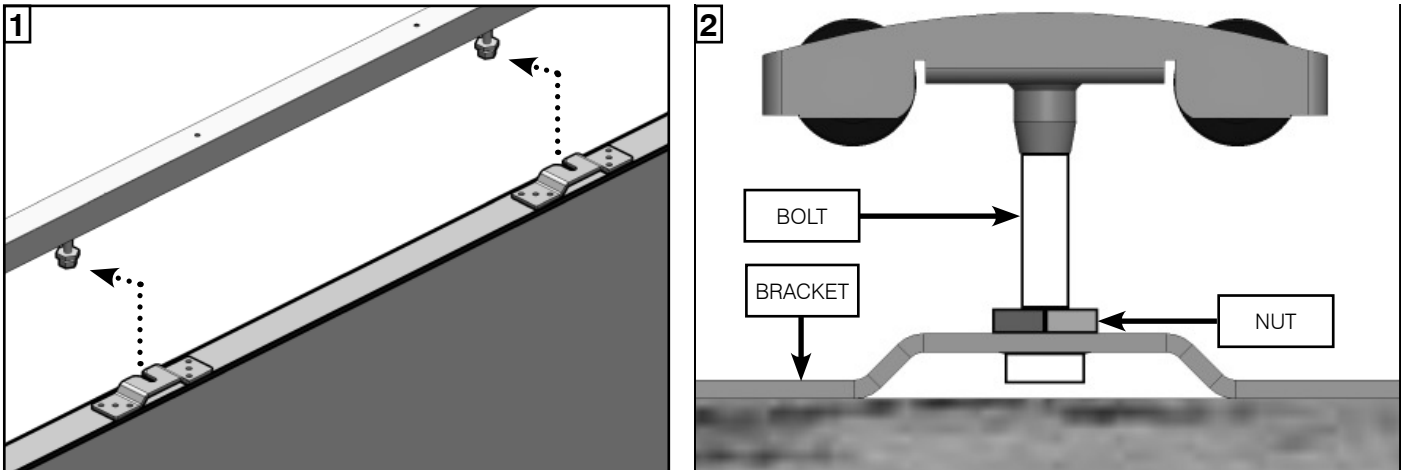

1. Hang secondary door by sliding the brackets onto the carriage bolts, taking care not to damage the belt or door on the door guide.
2. Tighten the top nuts onto the brackets to fix the trolleys into place.

14. PRIMARY DOOR HANGING

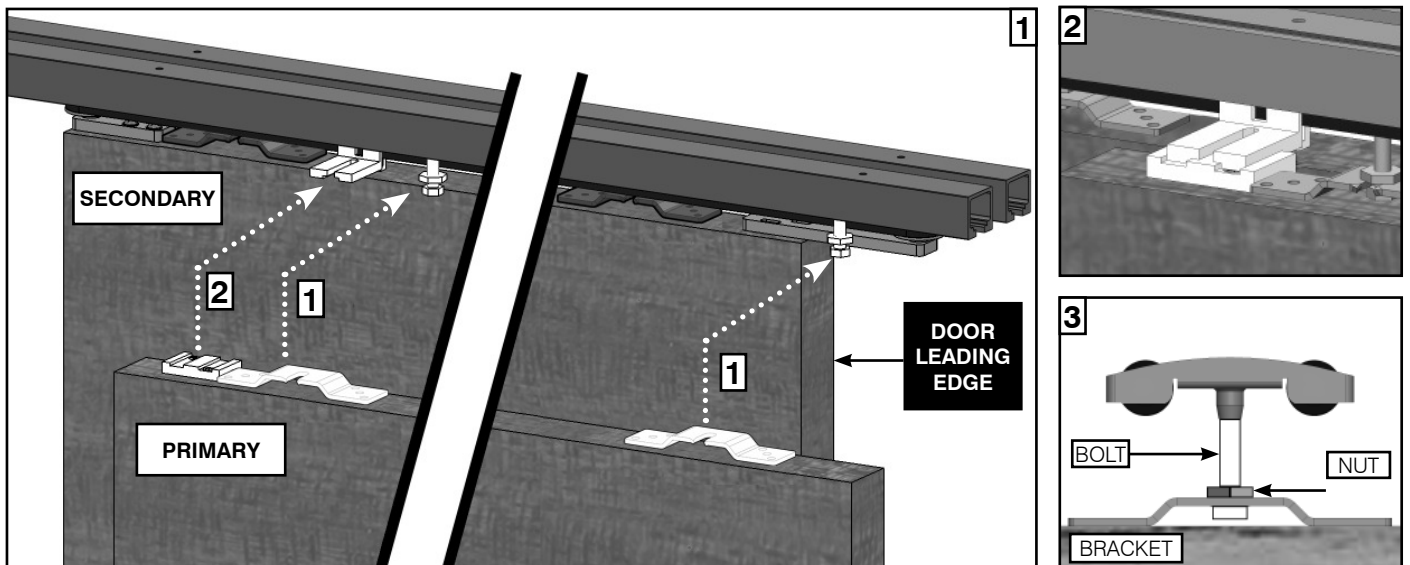

1. Hang primary door by sliding the brackets onto the carriage bolts.
2. Make sure the moving connector is placed into the moving connector bracket.
3. Tighten the top nuts onto the brackets.

TEST TO SEE IF THE DOOR RUNS SMOOTHLY AND IS PLUMB.

correct door operation by adjusting the carriage bolt using provided spanners;

Screw the carriage bolt in slightly to raise the door
Unscrew the carriage bolt slightly to lower the door

15. JAMB FITTING - CASSETTE JAMBS

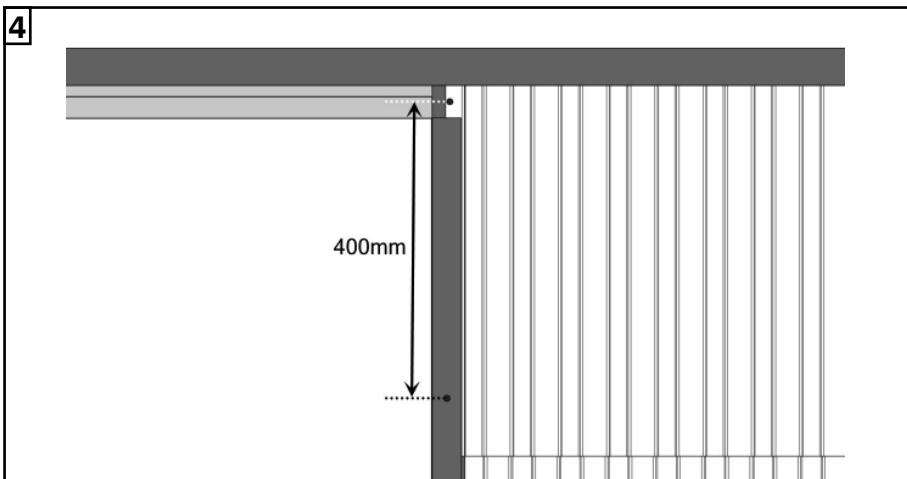
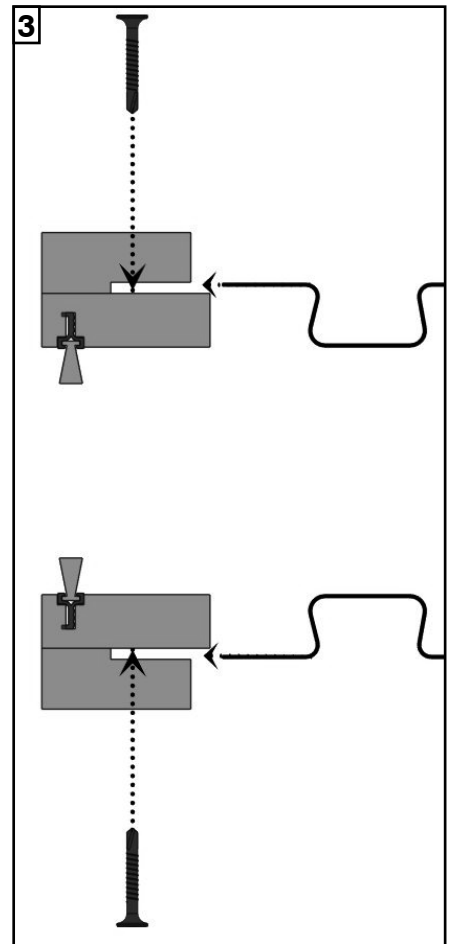
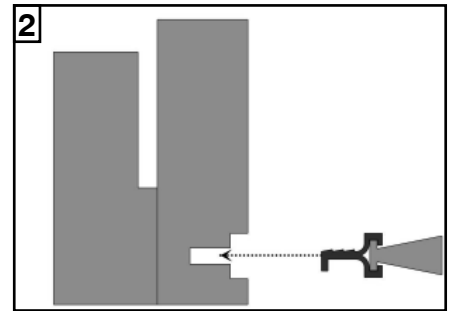
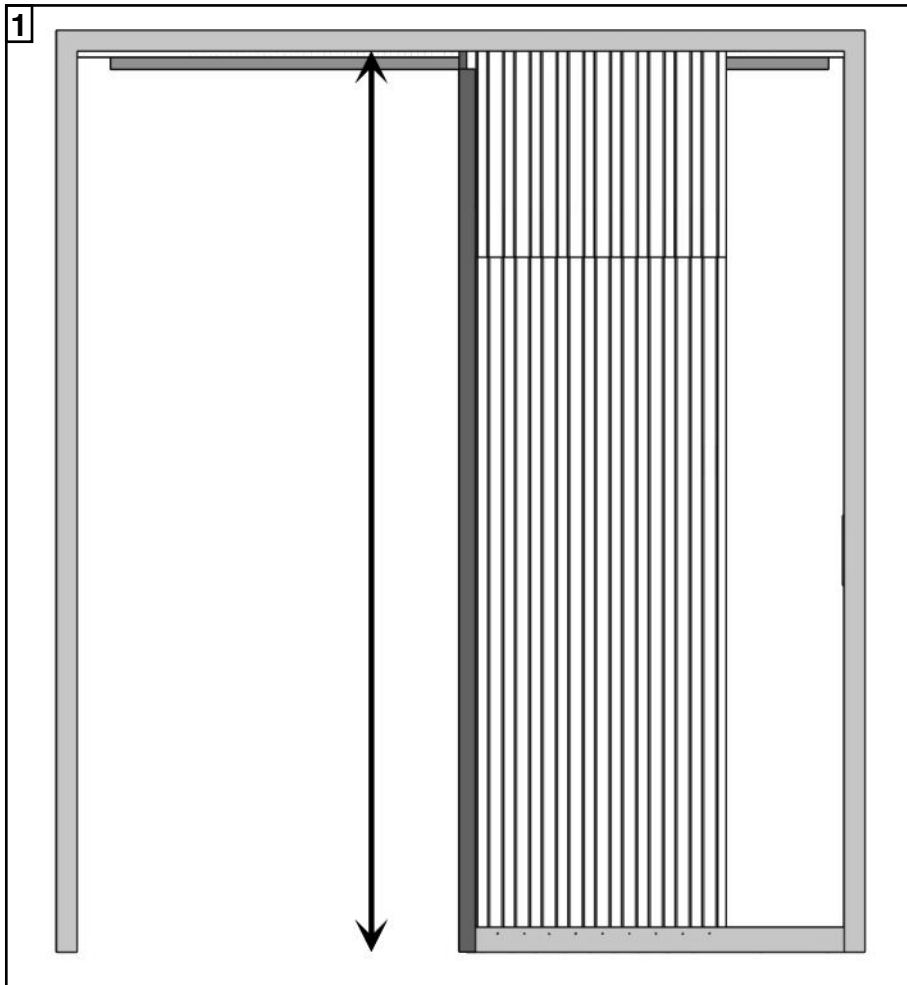

1. Cut cassette jambs to the studwork height from the finished floor to the underside of the stud. Ensure any cut is made at the end without the notch detail.
2. Push fit the brush seals into all cassette jambs.
3. Press the jambs onto the edges of the 'Z' sections and secure with 'Screw Set C'.
4. Screw at the top and bottom and then approximately every 400mm.

16. TRACK PACKERS

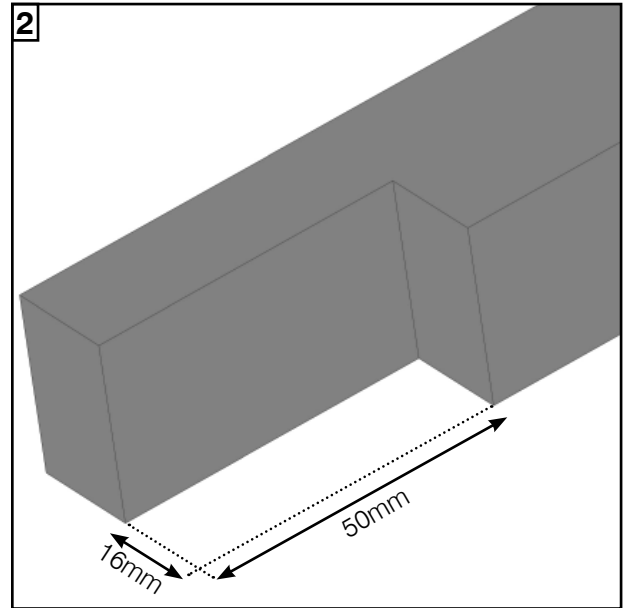
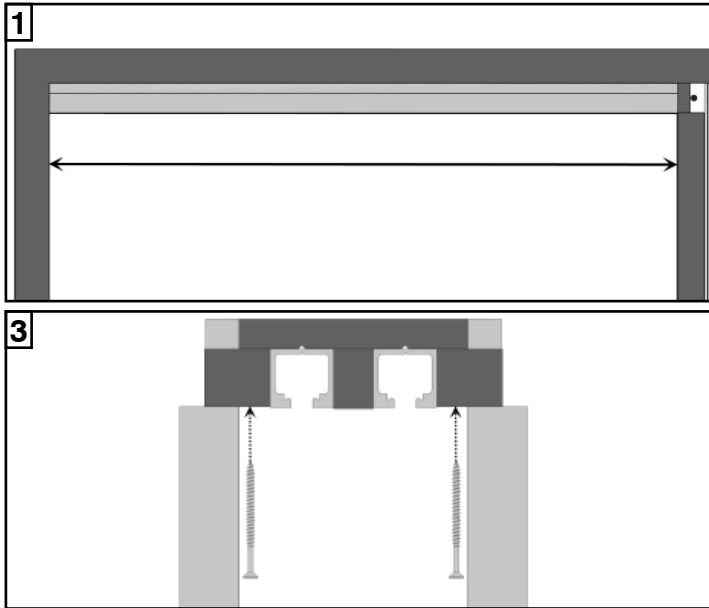

1. To cut the track packers, measure remaining door opening width between the cassette edge jambs and the studwork.
2. Cut a notch in one track packer as shown in image (50mm x 16mm). This is to be placed at the pocket end on the **secondary door side**.
3. To secure the track packers, first pilot and countersink a series of holes at 300mm intervals along their length. Screw through into the plywood track mount using **'Screw Set E'**.

17. CONNECTOR FITTING

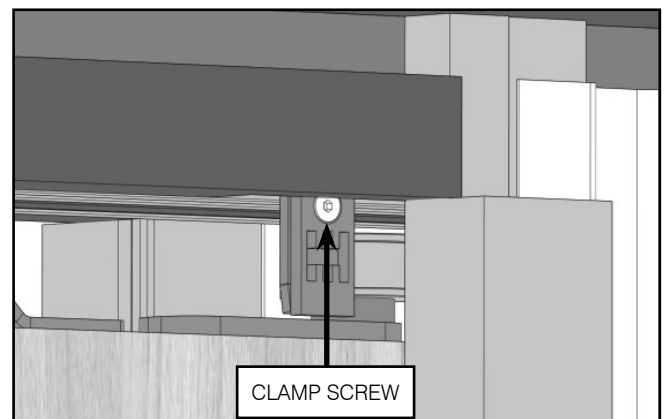
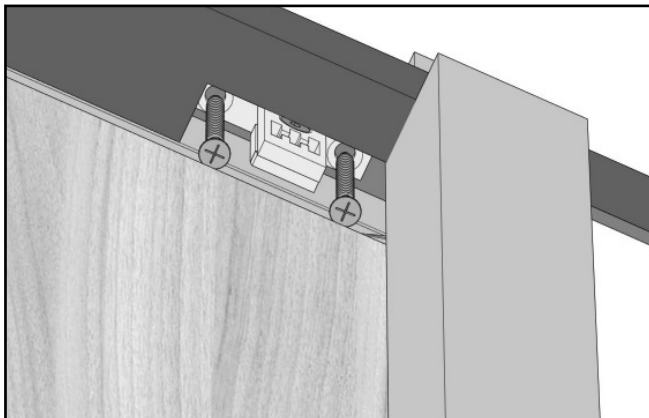

1. Screw fix the fixed connector into the space cut away in the track packer using the screws provided.

Close both doors fully out of the pocket and affix the clamp to the belt by loosening and re-tightening the clamp screw.

MAKE SURE THE CLAMP IS FACING INWARDS SO THAT THE BELT CAN BE POSITIONED CORRECTLY.

18. JAMB FITTING - FRONT EDGE JAMB

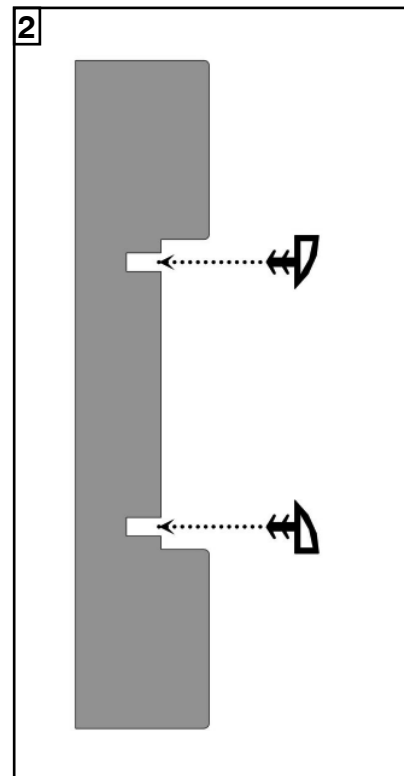
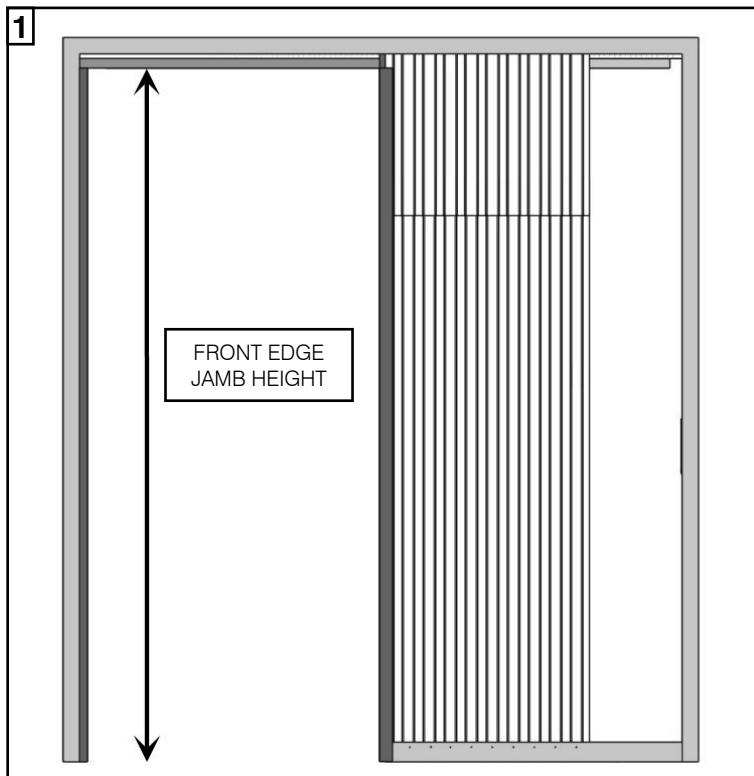

1. Using a sawing or cutting tool, cut the front edge jamb lengths to fit from the the floor to the underside of the track packers. Slide the door to its closed position to test fit. Secure to studwork with appropriate fixings.
2. Cut the rubber seals to the front edge jamb length and press into the pre-made grooves.

19. DOOR STOPS

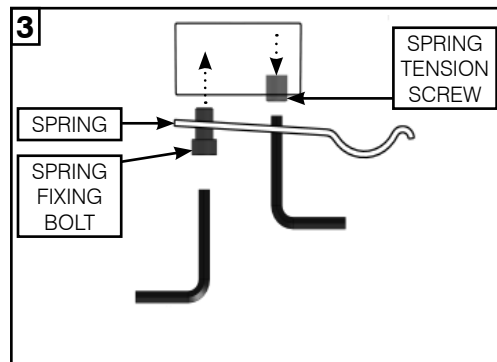
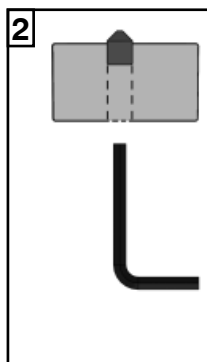
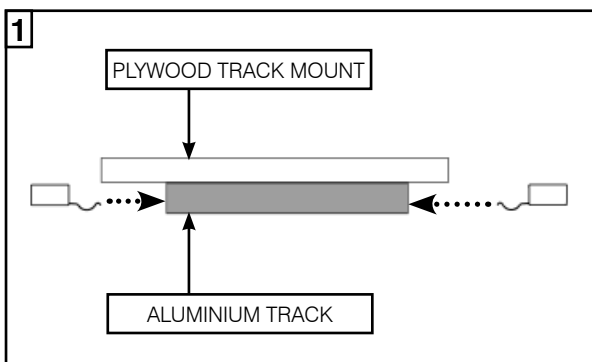

1. Place trolley catches at the front and back of the aluminium track (If not done already).
2. Fix trolley catches in required positions within the aluminium track by removing the spring giving access to the centre hole locking grub screw, use the provided 3mm allen key.
3. Replace the spring and adjust the clamping bolt to the desired tension to hold the trolleys in place, use the provided 4mm allen key.

20. HEAD SECTION FITTING

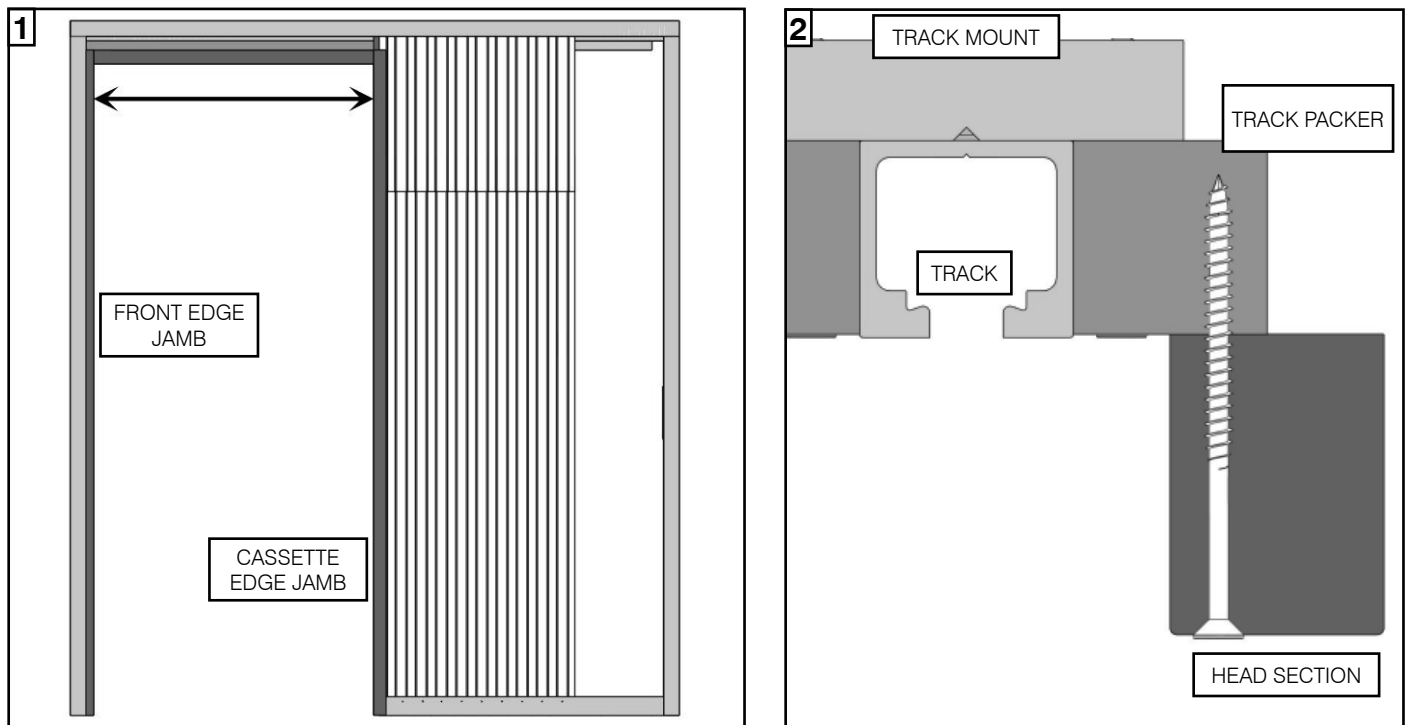

1. Cut the head section to fit between the front edge jamb and the cassette edge jamb.
2. A 70mm woodscrew is used to screw through the head section fixing into the track packer, the screws being approximately 300mm apart along the head sections length.
(fixings supplied)

INTERMEDIATE KITS

Fit the second set of 'Z' section sheets so that the rear edge is inline with the back of the pocket.

21. END BLOCKS

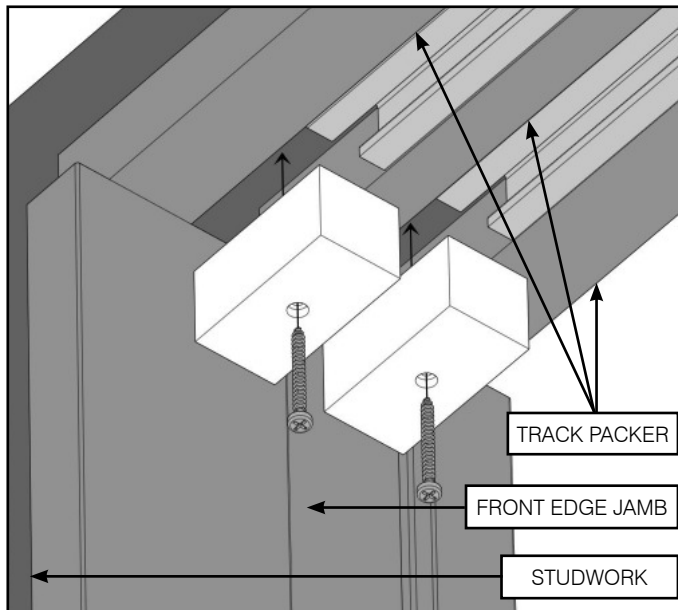

1. Pilot drill and counterbore a hole in the wooden end blocks using a 2mm drill bit. Drill the hole in the centre of each block.
2. Using the newly made holes, with **'Screw Set D'**, screw into the two spaces left between the aluminium tracks and the studwork. Make sure the end blocks are butted against the track.

22. PLASTERBOARD

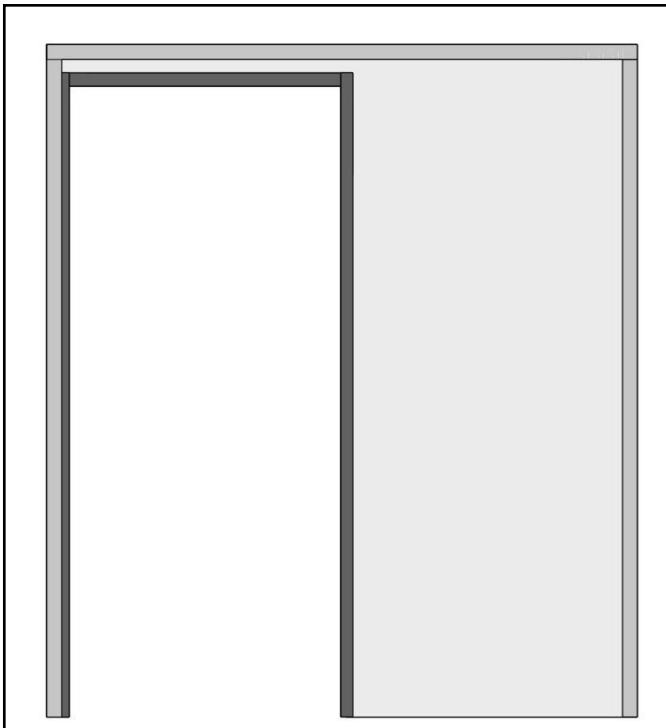

1. Clad the kit in 12.5mm of plasterboard. Ensure it butts up level and tight against all jambs.

When positioned correctly, use screw fixings to secure to the stud frame.
2. Pilot drill through the plasterboard and 'Z' section sheets a maximum of 300mm apart vertically and horizontally equal.

Screw the plasterboard into place.
(fixings not included)

**ENSURE NO SCREWS PROTRUDE
INTO THE POCKET CAVITY**